



SwiftConnect
Makes Installations
Swift & Fast.



ECOGENICA



- Do not install this if you cannot ensure that the power supply to the property is properly grounded.
- The device must be installed by a licensed professional and must meet the following conditions:
 - Complies with AS/NZS 3500.4 - "Plumbing and Drainage. Part 4: Heated Water
 - Compliant with control of hot water temperatures
 - AS 4032 AS NZS 3000-Electrical Wiring Rules.
 - Comply with the rules and regulations of the local authority.
 - In line with national building regulations.
 - Local occupational health and safety regulations.
 - Installation shall conform to the Plumbing Code of Australia (PCA)
 - Compliant with Australian Electrical Standard and the AS/NZS 1596:2002 Australian/New Zealand Standard™ The storage and handling of LP standards

WARNINGS

Eco Alliance Heat Pump units are subject to different installation regulations across different states in Australia. We will leave the decisions with you on how to proceed when installing the units ordered to best meet the regulations. Some best practice suggestions are below. They are only a minimum requirement and not limited to other regulations and practices you need to adhere to.

FOR THE CONTINUED SAFETY OF THIS APPLIANCE, IT MUST BE INSTALLED, OPERATED AND MAINTAINED IN ACCORDANCE WITH THE MANUFACTURER'S INSTRUCTIONS. PLEASE READ AND UNDERSTAND THIS MANUAL. IF YOU HAVE ANY QUESTIONS, PLEASE CONTACT OUR LOCAL DISTRIBUTOR.



WARNING Hot water burns! For safety, small children should be supervised around hot water appliances.

Since heat pump water heaters can generate water temperatures more than 50 degrees Celsius, regulations require that a **regulating valve be installed on the hot water outlet line** of the water heater, to prevent the water temperature from exceeding a pre-set safety upper limit. Water temperatures over 50 degrees Celsius can cause scalding, so care must be taken to ensure that damage is not caused by improper use of the water heater.

The installation must be performed by an authorized plumber with a gas handling license and maintained within requirements specified in of The Australian Plumbing Code. In case servicing the electrical or refrigeration systems in the Heat Pump please note, all service and repair work must be completed in accordance with the Australian/New Zealand Standard™ All electrical work should be completed to the relevant Australian Standards. The following Product Manual is a guide to the best practices regarding technician installation, service, and repair.

A heated water service means the point where the water heater connects to the cold-water service downstream of the isolation valve. Under no circumstances should "home craft" type modifications be attempted. Children should be supervised by a responsible person to ensure their personal safety. The system shall be leak-tested on completion of charging but prior to commissioning. A follow up leak test shall be carried out prior to leaving the site. Before carrying out this procedure, it is essential that the technician is completely familiar with the equipment and all its details The hot water pump power supply must be protected by a separate circuit breaker on the main power switch board and rated to suit the size of the components. Do not connect other appliances, especially high-power appliances, to the main power supply of the water heater, so as not to affect the normal use of the water heater Do not use means to accelerate the defrosting process or to clean, other than those recommended by the manufacturer. Do not install next to open flames, an operating gas appliance, or an operating electric heater. Do not pierce or burn piping. Be aware that R290 may not contain an odor. Compliance with national gas regulations shall be observed.

Compared to common refrigerants, R290 is a nonpolluting natural refrigerant with no harm to the ozonosphere greenhouse. R290 has got very good thermodynamic features which lead to high energy efficiency.

 <small>Caution: risk of fire</small>	Appliance filled with flammable gas R290		Before install the appliance, read the installation manual first.
	Before use the appliance, read the owner's manual first.		Before repair the appliance, read the service manual first.

||Directory Guidelines

<u>The first part: product info</u>	<u>3 -5</u>
<u>The second part: safety info</u>	<u>5- 6</u>
<u>The third part: before installation</u>	<u>7</u>
<u>The fourth part: installation</u>	<u>8-11</u>
<u>The fifth part: debugging</u>	<u>12-13</u>
<u>The sixth part: operation</u>	<u>13-16</u>
<u>The seventh part: trouble removal</u>	<u>16-19</u>
<u>The eighth part: maintenance</u>	<u>19-20</u>
<u>The ninth part: guarantee</u>	<u>21-22</u>

1||product info

1.1 Introduction

Your Ecogenica 290 FR model is a ground-breaking integral quick connect, direct heat transfer, Heat Pump Heating technology. That means Ecogenica is more reliable and energy efficient. And the innovation in our split condenser tank design is at the forefront of the industry right now. Designed and developed in Australia for Australian conditions by our design team who have been designing the most energy efficient Heat Pumps for more than 30 years.

Circulation pumps, and troublesome heat exchangers are not used, so fewer moving parts and no heat exchanger maintenance is required, making this a more reliable and resilient design compared to other heat pump water heater available. Your very high energy efficiency means superior energy saving compared to other Heat Pump Water Heaters. The Coefficient Of Performance (COP) of 4.8 means that for every 1 kW of power used from the grid (or from your solar power system) the Heat Pump put into the water 4.8 kW of effective power, by extracting heat energy from air. The 290 model is fully dedicated Heat Pumps and use the most advanced Reverse Cycle Heating Technology to heat the water instead of the air. The large surface area incorporated into the heat pump design means the Ecogenica does not need a heat element and will continue to extract heat from the air even in freezing weather.

Litres	Model #	Suitable for (people)	Tank Size (mm)		Heat Pump Size (mm)			Heating Capacity (kW)
			H	W	H	W	D	
290	EG-290FR290C	3-7	1815	510	545	780	276	3.4
290	EG-290FR290	3-7	1815	510	545	780	276	3.4

1.2 How does it work?

The secret to this physical process is the use of the naturally very cold R290a natural gas, which absorbs heat energy as it passes through the large heat pump fin coil. As the gas passes through the fin coil heat from the air turns the cold low pressure R290 vapor into a high-pressure gas, which then passes through a high efficiency rotary compressor, becoming super-heated. The Super-heated gas passes through a heat jacket which is wrapped around the water cylinder and once the gas loses heat energy to the water it turns back into a cold vapor and the cycle continues until the water is piping hot. You can expect the tank to heat up between 1 and 4 hours, wind, rain, snow, and summer.

The compressor compresses the gas, just like a bicycle pump (if you put your finger on it), and like the bicycle pump the gas get hot. The hot high-pressure gas then passes through the Micro-Channel condenser, which is located on the steel water heater. The Micro Channel Jacket heats the cylinder like an element heats a vitreous enamel frying pan. The Micro Channel Condenser Jacket is on the skin of the steel water cylinder under an inch of highly insulating foam, so the heat has nowhere to go except into the water. Best of all this means the jacket never encounters the water, and the direct heating process is more reliable and efficient than other heating technologies.

1.3 Natural Refrigerant

Ecogenica is at the forefront of Natural Refrigeration use, for a cleaner environment. Refrigeration mechanics are not required during installation, as the heat pump uses natural gas found commonly in the environment. R290a is (LPG) propane and as only 500 grams of propane is in the sealed system the heat pump contains just a fraction of that contained in a typical LPG BBQ bottle. To realize the function of the heat pump unit, a special refrigerant circulates in the system. The used refrigerant is R290, which is specially developed for Heat Pump use. The refrigerant is flammable and odorless. Furthermore, it can lead to explosions under certain conditions. But the flammability of the R290 natural refrigerant is very low and it can be ignited only by fire. Technicians must always turn on a combustible gas detector when entering the service area and make sure equipment power cords are unplugged or disconnected safely, as sparks from unplugging, or power disconnects could ignite flammable refrigerants. Service must also be performed in a well-ventilated area, especially if the refrigerant system is being accessed.

1.4 diagram

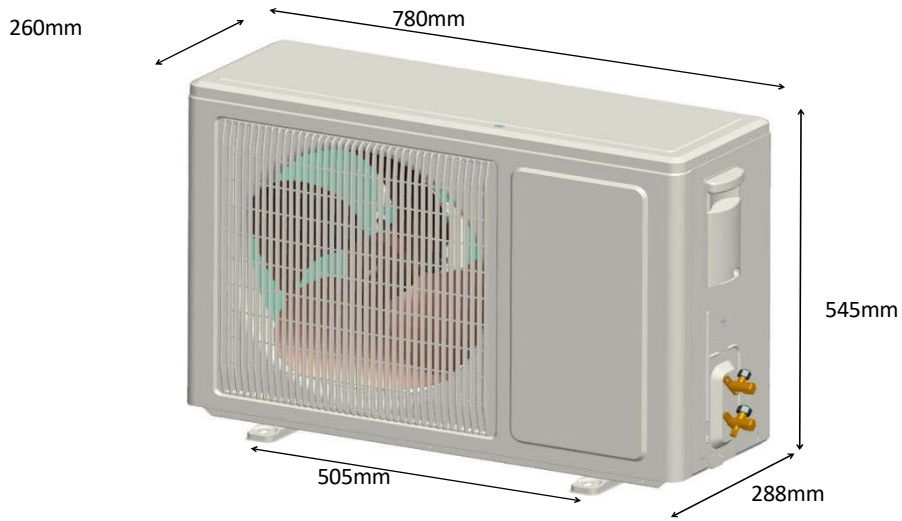

1.5 components

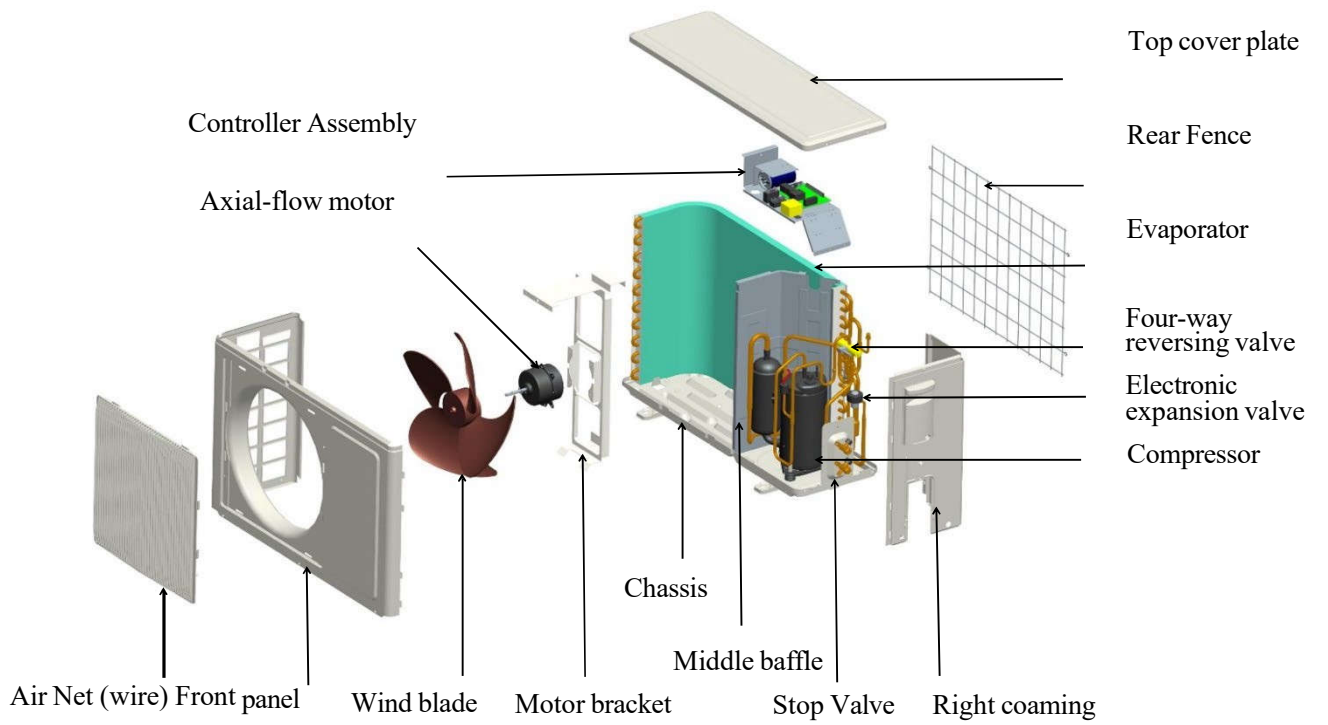

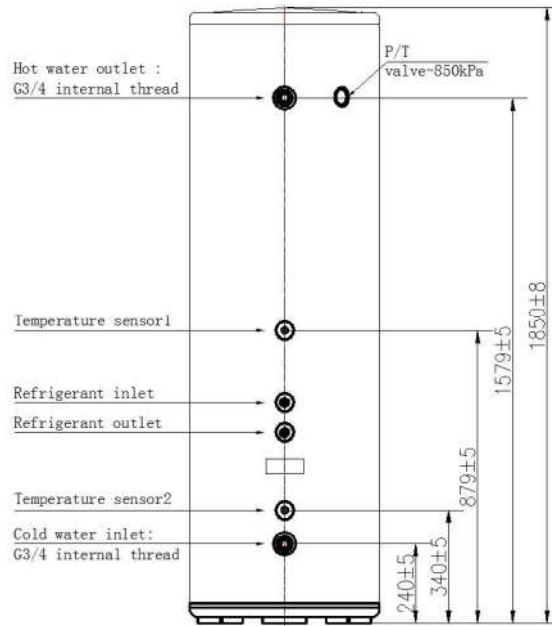

EG-290FR290 / EG-290FR290C

1.7 Parameters

Model	EG-290FR290 / EG-290FR290C	
Thermal capacity	3400W	
Average input power	700	
COP	4.85W/W	
Max power input	1150W	
Circuit Breaker Size	5.0A	
Refrigerant type	R290	
Mass volume	500g	
Running ambient air temp.	-7~+40℃	
Maximum outlet water temperature	70℃ (1℃ step)	
Product weight	36kg	
Tank weight	85kg	
Design Pressure (High)	3.0MPa	
Protection Raining Class	IPX4	
Rated pressure of water tank	850kPa	
Rated Pressure	500kPa	
PTR Valve	850kPa	
PTR valve power capacity	10kW	

Test condition:

Default setting: 55℃ Test conditions: outlet water temperature 55℃, inlet water temperature 14℃, dry bulb temperature 19℃, wet bulb temperature 15℃.

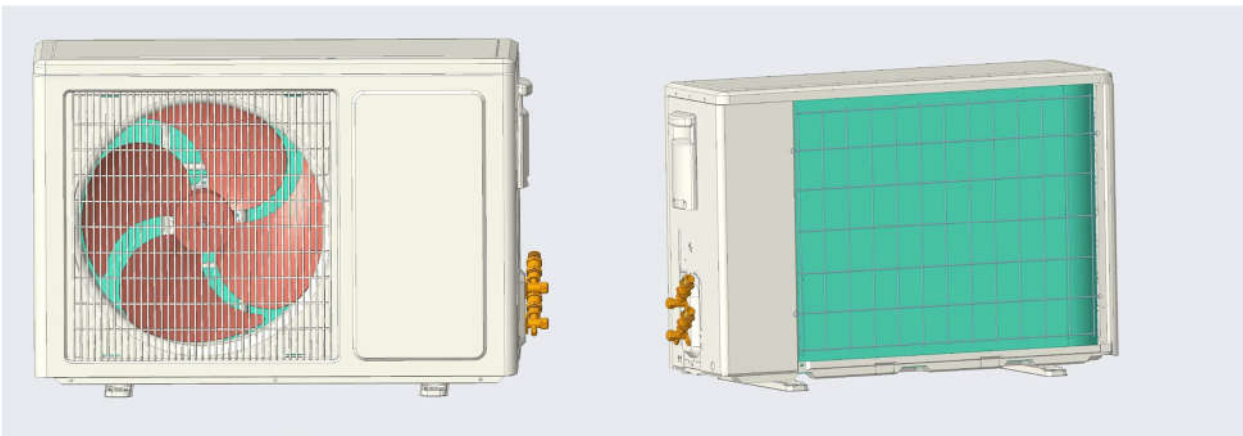
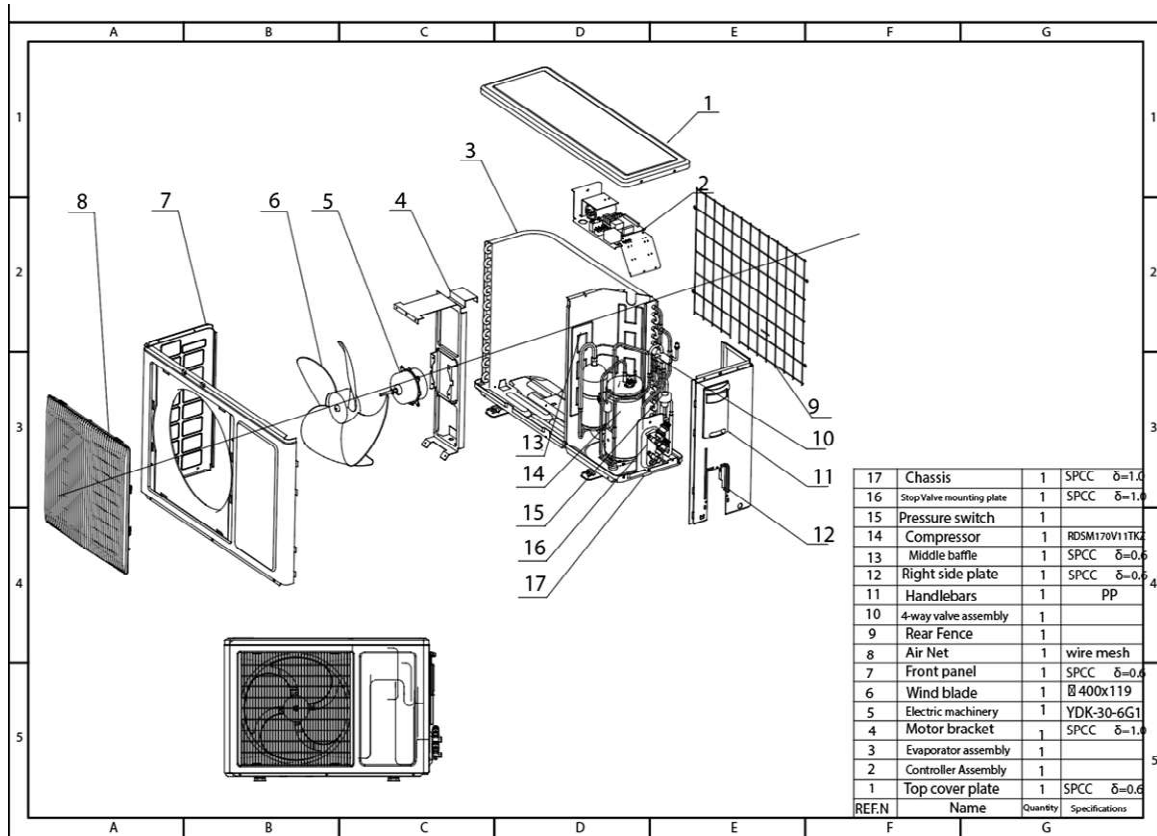

1-8 circuit diagram

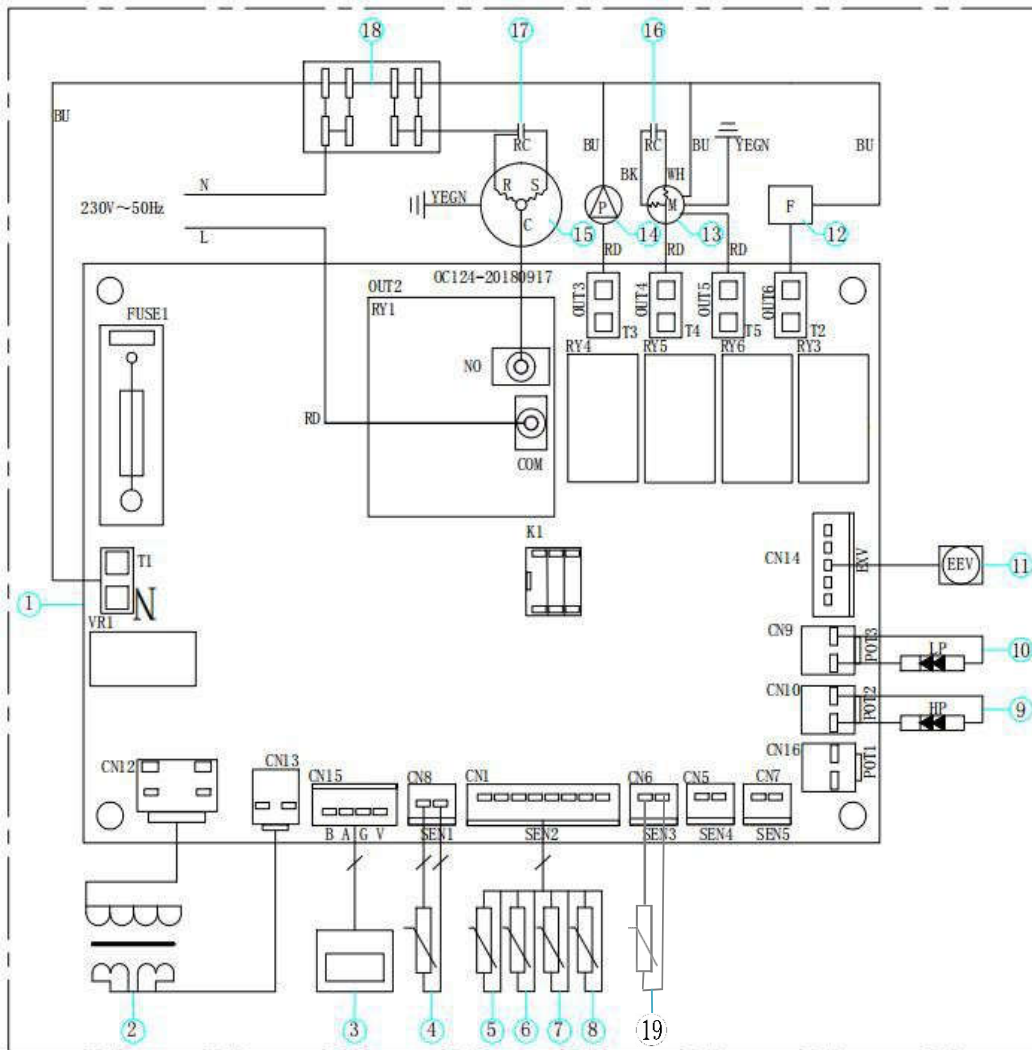

- | | |
|-----------------------------------|--------------------------------|
| ① Integrated Circuit Board | ⑩ Low-pressure switch |
| ② Transformer | ⑪ Electronic expansion valve |
| ③ Display | ⑫ Four-way reversing valve |
| ④ Water tank temperature sensor | ⑬ Motor |
| ⑤ Exhaust Temperature Sensor | ⑭ N/A |
| ⑥ Ambient Temperature Sensor | ⑮ Compressor |
| ⑦ Gas recovery temperature sensor | ⑯ Motor capacitance |
| ⑧ Coiler temperature sensor | ⑰ Compressor startup capacitor |
| ⑨ High-pressure switch | ⑱ Connection terminal station |
| | ⑲ Water tank temperature |

2||safety info

The following safety warnings are very important, always read and obey all safety signs:

warning

- Operation without water in the water tank may cause the water heater to enter a protection state, which may damage components in severe cases.
- This Heat Pump must be effectively grounded. RCD circuit breaker must be installed. Do not remove, cover, or damage any permanent instructions or labels from the exterior or interior of the unit panel.
- Only qualified personnel should install in accordance with local and national regulations and this guide. Improper installation may cause water leakage, electric shock, or fire alarm.
- All electrical connections must comply with the requirements of the local power company, the local power company, and this guide. Do not use a rated fuse, otherwise it may malfunction and cause electrical fire.
- Do not insert fingers, rods or other objects into the air inlet or outlet. The fan is rotating at high speed, which may cause injury. Do not use flammable sprays, such as hairspray or paint, near the machine to avoid fire.
- Disposal: Do not dispose of electrical appliances as unsorted municipal waste, A separate collection facility should be used. Contact your local government to find out Information about the collection system. If electrical appliances are disposed of at landfills or dump sites, hazardous substances can seep into groundwater and cause health problems question.
- The unit must be fixed firmly, otherwise noise and vibration may be generated.
- Make sure there are no obstacles around the device. In places with strong wind (such as seaside areas), the unit should be installed in a windproof place.
- The PTR valve is operated every 6 months to ensure that the valve does not have any restrictions.
- And it should be well insulated to prevent the water in the pipe from freezing in cold weather.

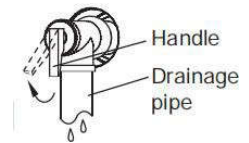

cautious

- The ground electrode must be well grounded. Make sure all electrical sockets and plugs are dry and tightly connected.
- Before cleaning the Heat Pump, be sure to stop operation and isolate the unit (i.e., turn off the isolating switch or circuit breaker). Otherwise, electric shock and injury may occur.
- Water temperature over 50 degrees Celsius will cause severe burns and even death. Children, the disabled and the elderly are at the highest risk of burns. In the bath or feel the water temperature with your hands before showering to avoid burns.
- Do not operate the machine with wet hands to avoid electric shock.
- A one-way check valve and a suitable isolation valve must be installed on the water inlet side.
- It is normal for the one-way safety valve to release some water during operation. However, if there is a large amount of water, please contact our service team. Arrange drainpipes to ensure efficient drainage. Improper drainage can cause water damage to surrounding areas such as buildings, furniture etc.
- Except for repair and maintenance purposes, do not turn off the power, especially in cold weather, as it may freeze the machine when the power is turned off. Continuously powered heating Water is necessary.



3 || before installation

3-1 disassemble

When unpacking, make sure that the items in the accessories list are complete, and whether the model of the main unit and the water tank are correctly matched.

3-2 transport

- When shipping this item, the following rules must be followed:
- When moving, do not make the fuselage deviate from the vertical angle by more than 25 Degrees keep vertical.
- To avoid scratches or damage, please use protective covering where applicable.
- Since the machine is heavy, it needs two or more people to carry it, to avoid injury and/or damage.

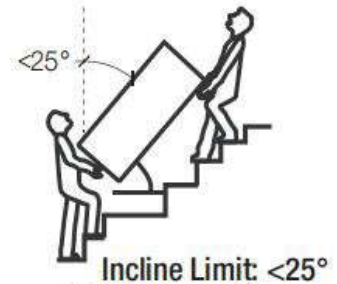

3-3 position requirement

When choosing a suitable location, the following factors should be considered:

- It is essential that electrical power is available before the task commences.
- Ensure that there is enough space for installation and future maintenance.
- The inlet and outlet should be free of obstacles and strong winds.
- The bottom surface should be flat (i.e., no more than 2° inclination), and can bear 3 times the weight of the machine, while ensuring that no noise and/or vibration will be increased.
- The running noise and the exhaust airflow should not affect other people.
- Make sure there is open no flame nearby.
- The installation location should be convenient for piping and wiring.
- Installation indoors may cause indoor temperature fluctuations and excessive noise.
- Ensure that the electrical insulation complies with the relevant local standards.
- The ventilation should safely disperse any released refrigerant and preferably expel it externally into the atmosphere.
- Prior to beginning work on, safety checks are necessary to ensure that the installation complies with relevant Australia Plumbing Codes.
- The area shall be checked with an appropriate refrigerant detector prior to and during work, to ensure the technician is aware of potentially toxic or flammable atmospheres.



cautious

The ambient air temperature must also be considered, the heat pump will not operate efficiently in temperature below 5 degrees, so day time operation should be considered and settings on the timer should be selected to provide adequate operation to heat the water. If it is installed in closed spaces such as garages and basements, there must be unrestricted air flow (such as installing a strong exhaust fan) to prevent freezing. Installing this unit in any of the following locations may cause malfunction (consult your representative before purchasing):

- Seaside areas or places with salt in the air.
- Hot spring areas with corrosive gases (e.g., sulfides).
- Factories with large voltage fluctuations.
- In a cabin without a large enough exhaust system.
- Places exposed to direct sunlight or other sources of high heat should be avoided and protection from direct sunlight (i.e. awnings should be considered).
- Areas with strong electromagnetic fields.
- Areas where flammable gases or materials are present.
- Areas where acidic or alkaline gases are present.

4|The installation

4-1 Piping drawing

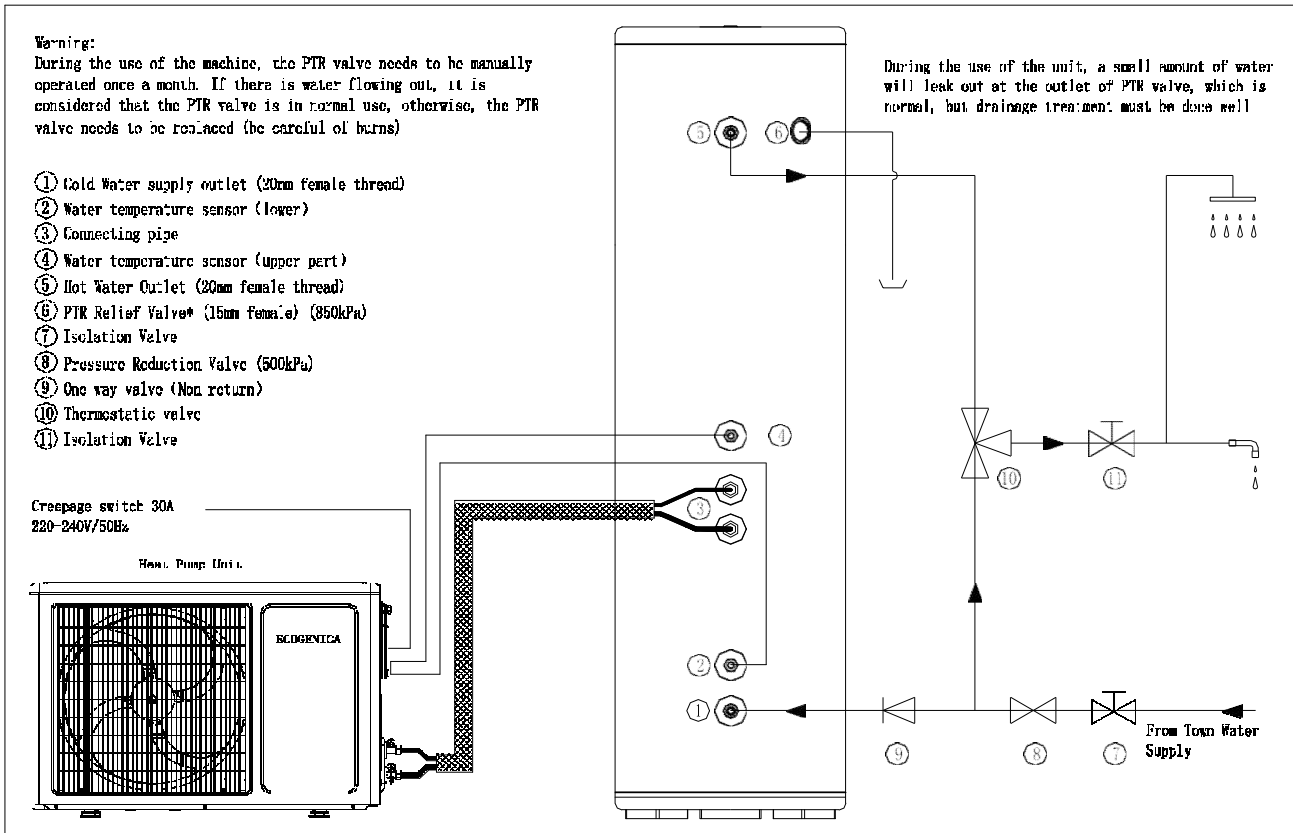

notice

- Cold water inlet and hot water outlet are 3/4-inch (20mm) female connections.
- The outlet of the PTR valve is a 3/4-inch (20 mm) female fitting.
- Supply outlets installed are either supplied in the Eco Alliance Quickie kit, or be an approved fixture as specified in the relevant Australian code and all installations must be completed to relevant Plumbing standards and meet relevant Performance Requirements and be compliant with documents such as AS/NZS3500.4 and the Australian Plumbing Code.
- Install a one-way valve at the water inlet of the water tank as described in the Australian Plumbing Code.
- All hot water pipes must have lagged that reduces heat losses to the highest standard.



cautious

- If the outdoor temperature is lower than 5 degrees Celsius during installation, insulation protection must be provided for hydraulic components (i.e., pipes).
- If the water inlet pressure is less than 150 kPa, a booster pump should be installed at the water inlet.
- To ensure the safe use of the water tank, when the water inlet pressure exceeds 500 kPa, a pressure reducing valve should be installed on the water inlet pipe.



warning

- Do not disassemble the PTR valve.
- Do not block the condensate drain line.

4-2 Install position

Install properly spaced air circulation and duct passages wall upper wall

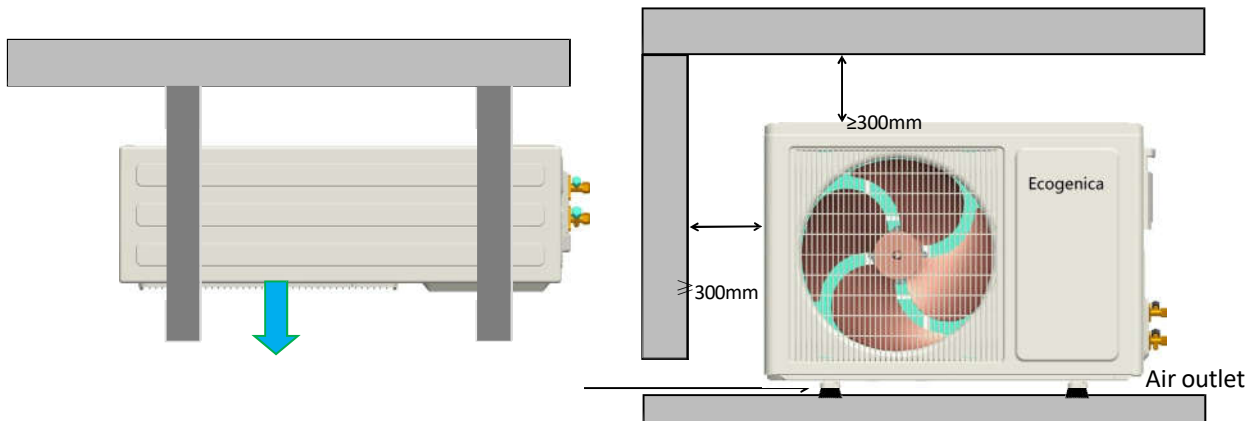

1. Installers need to firstly put the tank and condenser in place. The installer needs to work out the best layout strategy for the pipe and consider all site issues before lowering the condenser pipes.
2. Place the device on a flat, firm surface capable of bearing 3 times the weight of the device.
3. Locate the Heat Pump (Evaporator) within 2m from the Condenser Tank.
4. If there is no special drainage pipe (sink), be sure to ensure that the condensed water flowing on the ground can be drained smoothly to avoid water pooling around the heat pump. As condensate will otherwise drip from the appliance onto the floor if the drainpipe is not added.
5. Please do not pile up obstacles onto the Heat Pump, as they may affect the smooth air circulation (Should avoid the windward direction).
6. The outdoor unit (Heat Pump) is installed with a 25mm high rubber shockproof, and it is firmly fixed with studs to avoid noise when the machine is running.

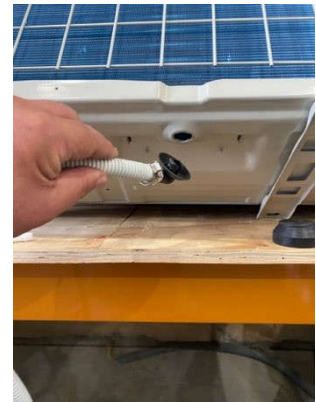

4-3 Water tank installation position

1. The water storage tank must be placed upright on ground, with a 10cm foot pad under it.
2. The installation site has a solid foundation and must be able to withstand a weight of more than 500kg. The tank should not be hung on the wall.
3. If the water storage tank is installed outdoors, in tropical climates, subject to server weather, please bolt firmly to protect against typhoon type weather.
4. Never install the wall bracket mounting support on the external walls of living areas, or bedrooms, as this may cause vibration type noise. Install the wall mounting support on a garage wall, for example.

4-4 Pre-charged refrigeration pipes

Connect the pre-charged refrigeration pipes using the (1/8" to 1/4") **quick connect adapter** supplied with the unit (in the quickie kit). The working fluid pipe: gas pipe is 3/8" (φ9.52), liquid pipe 1/4" (φ6.35)].



4-5 Connecting the couplings:

The EG Series comes standard with pre-charged 2-meter refrigeration lines for ease of installation and to prevent leaks.

Procedure for connection of the condenser pipe to tank:

1. Remove the packaging and carefully lower the refrigeration lines towards the heat pump. Connect the pre-charged refrigeration pipes using the (3/8" to 1/4") quick connect adapter supplied with the unit (in the quickie kit)
2. Guide the refrigeration line onto the female refrigeration quick connect adapter and prepare to screw the male coupling to the female coupling.
3. When connecting the water tank, please check whether the sealing nut of the water tank has fallen off, otherwise, use high-pressure nitrogen to clean the fluorine system channel.

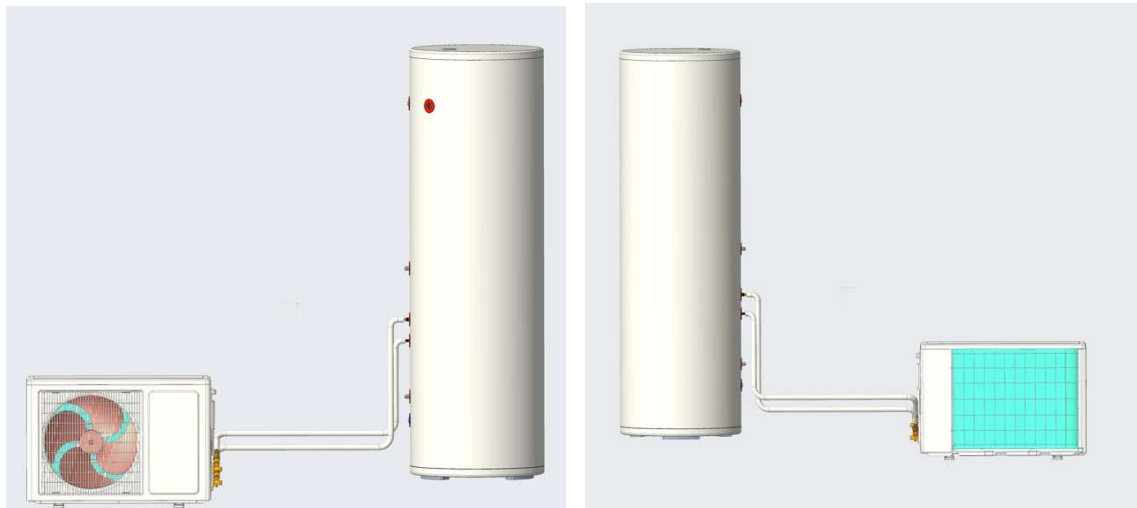

4. Once pressure is applied to the spanner the single use, one-shot coupling is folded back into the coupling, providing a high flow path and low pressure drop for the refrigeration charge in the condenser pipe (located on the water tank) to combine with the heat pump charge.
5. The couplings are connected and the refrigeration charge in the condenser pipe is released into the heat pump and the fully charged heat pump is ready for plumbing connections.

Residential installation

Notes:

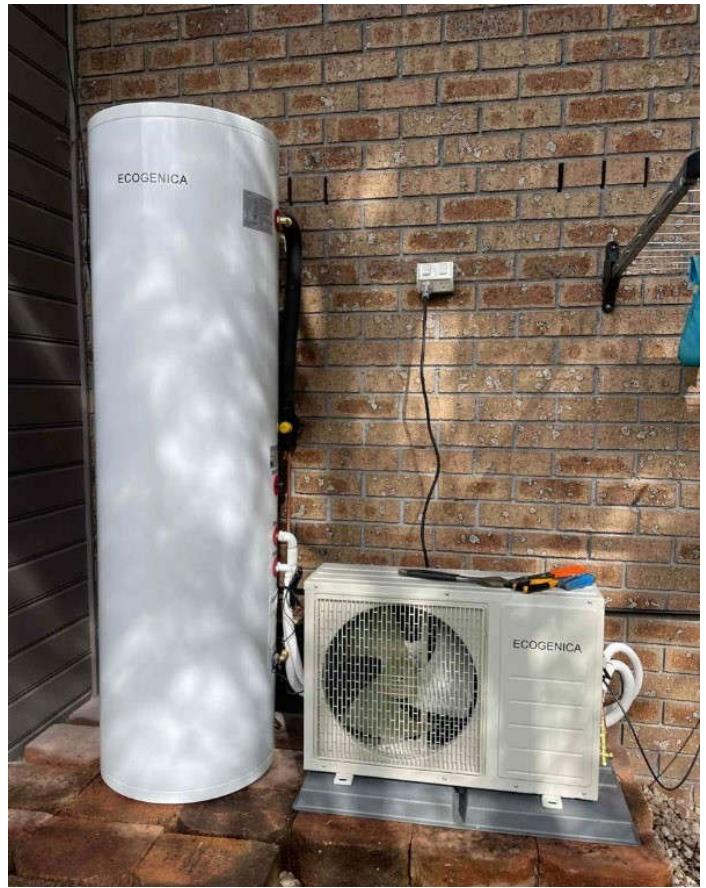

Small commercial installation

Notes:



4-6 Custom installations

If any customization is required, for example the pipes are to run under ground, through wall cavities, or walls, or to a heat pump on a roof, or bracket located above the tank; then a refrigeration mechanic should be arranged to complete the tank and heat pump connection, to the relevant Australian Standard.

Eco Alliance must also be notified, and approval must be secured from the Service Managers.

Extension pieces can be purchased, and this will enable an installer to extend the pre-charged connection by up to **5 meters**.

If extension pieces are purchased, because the tank and heat pump need to be further apart than the standard 2-meter condenser pipe will permit, these extensions must be purchased in advance. Installers must contact Eco Alliance to secure approval for any customized installation layouts

4-7 Electrical connections

- Electrical installation work may only be carried out by a licensed electrician in accordance with the relevant regulations on electrical safety and electrical wiring.
- Follow the wiring rules for circuit breaker rating are 20 AMPS, any installation under 20AMPS requires an RCBO to be connected
- The machine should use a special power supply, and the voltage should meet the rated voltage $\pm 10\%$
- The power supply circuit of the machine must have an effective ground (earth) wire, and the power ground wire must be reliably connected to the external ground wire.
- Power cables and signal cables should be arranged neatly and reasonably. Strong and weak cables should be separated from each other, and they should not interfere with each other. Otherwise, the normal state of the display will be affected.
- Please arrange the power supply layout reasonably and avoid splicing wires.
- Do not disconnect or disassemble the ground wire of the power supply under any circumstances; do not use damaged wires and switches and replace them immediately if they are found to be damaged.

Please refer to the table below

power specification	Wire diameter	switch	Leakage protector
220V~240V	2.5mm ²	20A	30mA

5 || Commissioning the system

5-1 Preparation before operation....

Before trial operation, please follow these steps before starting the machine, please confirm the following items, and mark them in the box after confirmation ✓

Trial run check list:

- Correct installation
- Piping and wiring are correct
- Drainage and emptying are smooth without leakage
- Plumbing installed correctly
- The power supply voltage is consistent with the rated voltage of the unit
- The air inlet and outlet of the unit are barrier-free
- Leakage protector works effectively
- Grounding is valid

5-2 System debugging

A trial run must be done after all installations are complete. Operation **without water** in the water tank may cause the water heater to enter a protection state, which may damage components in severe cases. **Failure to run the heater without water**, the manufacturer will not be responsible for any damage caused by this issue.

5-3 turn on power



cautions

- Before turning on the power to the unit, double-check that the water tank is full of water.
- After confirming that the power cord is firmly connected, turn on the power of the water heater.
- No need to operate the display, the display is in the power-on state by default.
- The device has a three-minute delay start function, please be patient. After running for 30 minutes, observe the running status.
- If there is any problem, please check the display. The fault code displayed on the screen and timely feedback.
- The device is fully automatic control, according to the selected method and the surrounding environment, the set water temperature, self-adaptive adjustment, heating the stored water to target temperature.
- At all times the manufacturer's maintenance and service guidelines shall be followed. If in doubt, consult the manufacturer's technical department for assistance.

5-4 Electrical Services Guide

- The electrical components such as the fan motors, overloads, and start device are sealed to prevent them from igniting R-290. However, all service work should be conducted only after approval from Eco Alliance has been secured.
- All service and repair work must be completed in accordance with relevant Australian Electrical Standard and the AS/NZS 1596:2002 Australian/New Zealand Standard™ The storage and handling of LP standards and all other relevant Australian Standards.
- If it is necessary to have an electrician provide servicing, the electrician must not work on Heat Pump components, or circuits, until inspected by an Eco Alliance approved technician, to ensure that no leaks are present.
- It's recommended that service agents contact Eco Alliance, Phone 1300 341 010 to gain approval for the heat pump to be disconnected and returned to Eco Alliance; instead of conducting electrical works on components and circuits contained within the Heat Pump.
- If the system has been identified as having a gas leak, then the Eco Alliance approved technician must ensure that the Heat Pump has been evacuated.
- Once approval for onsite repairs has been secured from Eco Alliance, repair and maintenance of electrical components shall include initial safety checks and component inspection procedures.
- If the fault in the power supply cannot be corrected immediately, but it is necessary to continue operation, an adequate temporary solution shall be used. This shall be reported to the owner of the equipment, so all parties are advised.
- If during service and repair, the capacitors must be discharged to avoid electrical shocks. This should be done in a safe manner to avoid the possibility of electrical sparks. Inspect that no live electrical components and wiring are exposed while charging.
- Particular attention shall be paid to ensure that by working on electrical components, the protective casing on all electrical components is not altered in such a way that the level of protection is affected. This shall include damage to cables, excessive number of connections, terminals not made to original specification, damage to seals, incorrect fitting of glands, etc.
- Ensure that seals or sealing materials have not degraded to the point that they no longer serve the purpose of preventing the ingress of flammable atmospheres. Replacement parts shall be in accordance with the manufacturer's specifications.
- Do not apply any permanent inductive or capacitance loads to the circuit without ensuring that this will not exceed the permissible voltage and current permitted for the equipment in use. The test apparatus shall be at the correct rating.
- Check that cabling will not be subject to wear, corrosion, excessive pressure, vibration, sharp edges, or any other adverse environmental effects. The check shall also consider the effects of aging or continual vibration from sources such as compressors or fans.
- If any hot work is to be conducted on the refrigerating equipment or any associated parts, appropriate fire extinguishing equipment shall be available to hand. Have a dry powder, or CO2 fire extinguisher adjacent to the charging area.
- All possible ignition sources, including cigarette smoking, should be kept sufficiently far away from the site of installation, repairing, removing and disposal, during which refrigerant can possibly be released to the surrounding space.
- Prior to work taking place, the area around the equipment is to be surveyed to make sure that there are no flammable hazards or ignition risks.
- "No Smoking" signs to be displayed if risk of contact with the public in the immediate area of the system.

5-5 Refrigeration Service Guide

- All service work should be conducted only after approval from Eco Alliance has been secured and service and repair technicians must be aware of Eco Alliance repair and service procedures.
- In case of a refrigerant leak all service and repair work must be completed in accordance with the AS/NZS 1596:2002 Australian/New Zealand Standard™ The storage and handling of LP standards and all other relevant Australian Standards.
- No person carrying out work in relation to a refrigerating system which involves exposing any pipe work shall use any sources of ignition in such a manner that it may lead to the risk of fire or explosion.
- It's recommended that service agents contact Eco Alliance, to gain approval for the heat pump to be disconnected and returned to Eco Alliance; instead of conducting refrigeration and electrical works on components and circuits contained within the Heat Pump.
- If in a commercial or industrial setting, then all maintenance staff and others working in the local area shall be instructed in the nature of the work being carried out. Work in confined spaces shall be avoided.
- It is recommended good practice that the R290 Natural gas systems are not recovered. As they are flammable caution must be taken to ensure sparks and open flame is not close to the service site.
- All refrigerants are if not R290 must be recovered safely. Prior to the task being carried out, ensure that:
 1. Recovered refrigerant shall not be charged into another refrigerating system unless it has been cleaned and checked.
 2. Equipment shall be labelled stating that it has been de-commissioned and emptied of refrigerant.
 3. The label shall be dated and signed
 4. Ensure that there are labels on the equipment stating the equipment contains
- Ensure that the leak detection equipment being used is suitable for use with all applicable refrigerants, i.e., non-sparking, adequately sealed or intrinsically safe.
- Recovering or purging the system must comply with all relevant Australian Codes. During repairs to sealed components, all electrical supplies shall be disconnected from the equipment being worked upon prior to any removal of sealed covers, etc.
- Ensure that the detector is not a potential source of ignition and is suitable for the refrigerant used. Leak detection equipment shall be calibrated to the appropriate percentage of gas. Electronic leak detectors may be used.
- If a leak is suspected, all naked flames shall be removed/extinguished. If a leakage of refrigerant is found which requires brazing, all the refrigerants shall be recovered or removed from the system.
- When breaking into the refrigerant circuit to make repairs – or for any other purpose – conventional procedures shall be used, for flammable refrigerants, it is important that best practice is followed since flammability is a consideration.
- If recovery equipment is used ensure it is in good working order with a set of instructions concerning the equipment that is at hand and shall be suitable for the recovery of flammable refrigerants.
- Check that it has been properly maintained and that any associated electrical components are sealed to prevent ignition, in the event of a refrigerant release. Consult manufacturer if in doubt.
- If compressors or compressor oils are to be removed, ensure that they have been evacuated to an acceptable level to make certain that flammable refrigerant does not remain within the lubricant. The evacuation process shall be carried out prior to returning the compressor to the suppliers. When oil is drained from a system, it shall be carried out safely.

5-6 Machine running dynamics

There are different heating times at different ambient temperatures.

Typically, lower ambient temperatures result in longer run times.

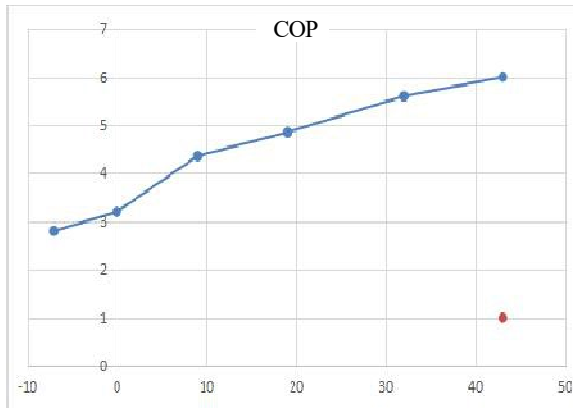
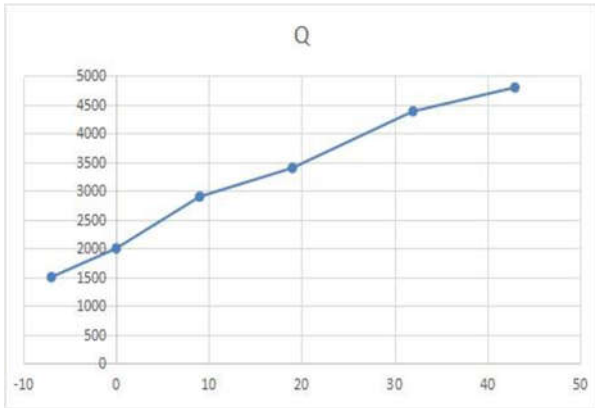

Changes in ambient temperature and heating capacity

Changes in ambient temperature and energy efficiency ratio

Note: The above data is measured in the laboratory to simulate the ambient temperature and humidity. If it is different from the actual ambient temperature and humidity, this data is for reference only.

5-7 Protection method

When the self-protection mode is activated, the system will stop and start self-checking. Once the error is resolved, the unit will restart. When the self-protection mode is activated, the error code will be displayed on the screen until the error is resolved.

- The device can enter self-protection mode under various conditions, including but not limited to:
 - Blocked air inlet or outlet.
 - The evaporator is covered with too much dust.
 - The unit receives incorrect power (over the 220-240v range)

5-8 Natural Refrigerant addition

The working medium pipe equipped with the main engine is the base length. When the length exceeds the base standard length, the refrigerant must be added strictly according to the length of the working medium pipe.

Additional refrigerant is required. Please follow the table below, adding will affect the performance of the unit

Refrigerant addition	record
0.015kg/m× (L- base length)	



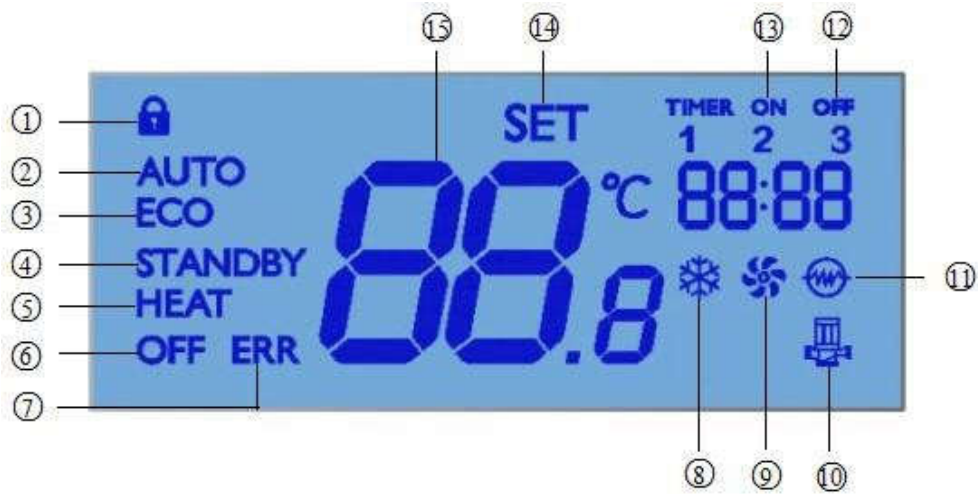

Note: L is the length of the double-pass working fluid tube, in mm. After adding, please record the final charging amount and keep it properly for subsequent maintenance.

6||System operation

6-1 display









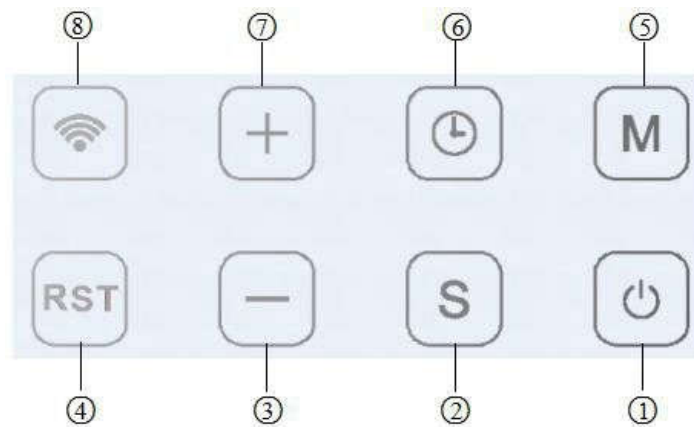

1		Lock: (this function is blocked) If the control panel is locked, the lock icon will be displayed on the screen
2	AUTO	Auto Mode: If auto mode is selected, this icon will be displayed on the screen
3	ECO	Economic model: This icon will be displayed on the screen if the economy mode status is selected
4	STANDBY	Insulation: If the machine stops working when the water temperature has reached the set temperature, this icon will be displayed on the screen
5	HEAT	Heating: This icon will be displayed on the screen when the machine is on and working to produce hot water

6	OFF	Shutdown: This icon will be displayed on the screen when the machine is off
7	ERR	Fault: When the machine automatically detects fault feedback, this icon will flash on the screen
8		Defrost: This icon will be displayed on the screen when the machine is in defrost state
9		Fan: This icon will appear on the screen when the fan is running
10		Water pump: Is not required and is not available with these models
11		Electric heating: Is not required and is not available with these models
12	OFF	Timed off: This icon will be displayed on the screen if the timed power-on function is canceled
13	ON	Open regularly: This icon will be displayed on the screen if the timed power-on function is performed
14	SET	Set temperature: When the desired unit temperature is set, the set temperature icon will be displayed on the screen
15		When the control panel is not working, the water temperature setting will display the current water temperature in the tank; when the desired temperature is set, the water temperature setting will display the desired temperature

6-2 The control panel





1		Start the device: Turn on the machine and press and hold the power button for 3 seconds. The display "HEAT" flashes. Turn off the device: Turn off the machine, press and hold the switch for 3 seconds. Display "OFF" display;
2		Setting parameters: When you need to set the water temperature or other parameters, press this key to proceed; Press and hold for 10 seconds to enter forced defrost;
3		reduce: To lower the set temperature or reduce a certain value, press this key to proceed;

4		Reset: Press this key to reset to the original factory setting parameters;
5		model: Press and hold for 3 seconds to activate the electric heating function;
6		Time setting: press this key to set the current time. Set timed power on/off;
7		Increase: To increase the set temperature or increase a certain value, press this key to proceed;
8		This key is invalid

6-3 key operation instruction





Start up:

- power on press "" for 3 seconds
- power off press "" for 3 seconds









Temperature set:

- press "+" or "-" to set the temperature and adjust temperature
- press "" to save your set and then quit.





Time set:

- press "" to set time as follows: hour -clock-quit
- press "" and "" to set the time details.
- without pressing keys for 30 seconds, the machine will quit automatically
- during the set process, you can press "" to quit:

Timer switch set :

- press "" for 3S to come into the setting
- timing 1: timing 1 flicks, press "" and "" to set hours and press ""; timing 1 flicks, and press "" and "" to set the minutes , and press ""
- timing 2 : press "" to come into timing 2, and way is as the same as timing 1 ;
- timing 3: same way as above.
- without any action for 30seconds, it quit automatically.
- press "" to quit if no action needed.

factory parameter setting:

- Press "(RST)" 3 times continuously to come into the data setting, press "" or "" to set and then press "" to confirm your setting.
- without any actions for 5 seconds, the machine will quit automatically
- press "" to quit if you do want to do any action.

Parameters restore factory default parameters

- press "(RST)" for more than 4 seconds, when it shows "dEF", press "" to become factory default parameters

Manual forced defrost

- press “

- 20 -

Refrigerant recovery

- press “S” for 3 times continuously , press “▲” or “▼” to come to F98, then press “S” to show “AdF”,

After the machine is started, first close the low-pressure shut-off valve, then close the high-pressure shut-off valve after the machine runs for 1 minute, and finally press any key to exit this mode

- Disconnect the power supply to prevent the machine from starting up in the event of a system blockage

Legionella control method – provide details of control strategy:

- Compressor is activated automatically once week to heat 90% of the tank once a week 61 °C, for 32 min.

7|| System Trouble shooting

7-1 Fault code

	Content	Fault code	Heat Pump status	Notes
①	Freeze Protection	A11		
②	Low voltage switch protection	A12	stop heating	power off then power on
③	High voltage switch protection	A13	stop heating	power off then power on
④	Water tank temperature sensor failure	A21	stop heating	Automatic recovery
⑤	Coil temperature sensor failure	A22	-	Automatic recovery
⑥	Exhaust temperature sensor failure	A23	-	Automatic recovery
⑦	Ambient temperature sensor failure	A25	-	Automatic recovery
⑧	Intake air temperature sensor failure	A26	-	Automatic recovery
⑨	Operator cable interruption protection	A51	stop heating	When the VCC and GND lines are opened, the operator does not light up; when the A and B lines are opened, the operator displays the A51 fault code.
⑩	Exhaust temperature high temperature protection	A61	stop heating	3 times/hour the heat pump stops Working.

7-2 trouble shooting

Problems	Reasons	Solution	Phenomenon
Freeze protection A11	Water temperature $\leq 4^{\circ}\text{C}$ for more than 5 minutes or ambient temperature $\leq 2^{\circ}\text{C}$ and the shutdown time exceeds 15 minutes	machine will automatically detect and return to normal.	Make sure the water volume of the water tank, the
Low voltage switch protection A12	1. The terminals of the low voltage switch fall off or have poor contact or are damaged;	1. Check the circuit board port;	After 3 occurrences within 1 hour, the machine will automatically stop working, and it needs to be powered on again to resume the
	2. Lack of snow seeds. 3. The ambient temperature is lower than -7°C ; The electronic expansion valve is not open;	2. Check whether the operating pressure is lower than the standard value of the pressure switch. 3. The working environment has exceeded the limit of operating range of the compressor.	Check whether the electronic valve coil and ports are loose.
High voltage switch protection A13	1. The terminal of the high-voltage switch has fallen off or is in poor contact or is damaged. 2. Water shortage (the pump does not work); 3. The filter is blocked. 4. The electronic expansion valve is not opened. The water tank temperature sensor is not placed in the water tank, resulting in a misjudgment, which does not match the actual water temperature;	1. Check the port of the circuit board. 2. Check the amount of water in the tank. 3. Enter the forced defrosting function, reverse the flush for 1min. 4. Check the coil and end of the electronic valve, check the to see if the mouth is loose.	After 3 occurrences within 1 hour, the machine will automatically stop working, and it needs to be powered on again to resume the re-detection;
Tank temperature sensor A21	1、 break or short circuit ;	1、 Replace the sensor	Machine stop working
Coil temperature sensor A22	1、 break or short circuit;	1、 Replace the sensor	The machine can run normally, but cannot enter or exit the defrost
Exhaust temperature sensor A23	1、 break or short circuit;	1、 Replace the sensor	The machine can run normally, but the high temperature protection fails

Environment temperature sensor A25	1、 break or short circuit;	1、 Replace the sensor	Machine works normally, but cannot enter or exit the defrost
Suction temperature sensor A26	1、 break or short circuit;	1、 Replace the sensor	Machine works normally

Operator cable interruption protection A51	1. The connecting line of the operator is open or short-circuited	1、 Replace the sensor	When the VCC and GND lines are connected, the operator does not light up; when the A and B lines are connected, the operator displays the A51 fault code, and the machine stops working;
Exhaust temperature high temperature protection A61	1. Check whether the system lacks refrigerant, check the system leaks and make up for them in time;	Check the water volume and temperature of the water tank and confirm compressor is running and shutting off at the correct set point.	After 3 occurrences within 1 hour, the machine will automatically stop working, and it needs to be powered on again to resume the re-detection;

Shows running, but not heating	<ol style="list-style-type: none"> 1. The compressor does not work (Overload or burn out); 2. Four-way valve gasping. 3. In the cooling state (defrosting); lack of snow seeds; 	<ol style="list-style-type: none"> 1. Check whether the compressor line is loose and measure whether the resistance of the compressor main winding and auxiliary winding is normal. 2. Judgment of painting of the four-way valve: check if the temperature of the exhaust pipe is the same as the temperature of the intake pipe, it is regarded as a panting phenomenon. 3. Judgment of cooling status: the water temperature continues to cool down; the fan continues to blow hot air
Heating, fan not running	1. The motor capacitor is damaged; The motor is burned out or the power	Replace the motor or capacitor

Compressor is noisy	<ol style="list-style-type: none"> 1. Water shortage (the pump does not work), the temperature difference is too large. 2. The compressor is fixed too tightly, and the rubbing vibration space is small; The operating voltage has exceeded the range of 198V~242V; 	<ol style="list-style-type: none"> 1. Ensure that there is sufficient water. 2. The distance between the control nut and the top of the compressor damping rubber. Increase the voltage regulator to ensure that the voltage is normal;
Product is noisy	<ol style="list-style-type: none"> 1. The pipeline vibrates greatly. If the distance between the parts is too small, it is easy to cause collision and friction; 2. Check that the fin coil or fan protection are not vibrating. 	<ol style="list-style-type: none"> 1. Vibration-absorbing rubber is added to the pipe fittings. 2. Adjust the distance between components and pipes. 3. Insert a rubber between the fan protection mesh and the fin coil.
User water temperature is low	<ol style="list-style-type: none"> 1. The amount of cold water mixed with water is large, and the output of hot water is small; 	<ol style="list-style-type: none"> 1. Adjust the mixing valve to control the ratio output of hot water and cold water;
The diagnostic codes and usage symptoms listed above are the most common		if the diagnostic codes listed above or other usage issues do not appear, please contact technical assistance

8||system maintenance

8-1 cleaning

- The heating effect depends on whether there is dust, mud or other on the surface of the evaporator
- A blocked air inlet channel will reduce the heat pump's ability to absorb heat from the air, resulting in loss of heating efficiency.
- It is necessary to clean the dust, or other impurities from the surface of the evaporator to ensure that the Air intake and Heat Pump are blowing are unobstructed.
- Be sure to turn off the heat pump unit before cleaning (Disconnect the power supply directly)



- **Cleaning methods include**

- Water flushing: first wash away the dust or other impurities on the surface
- Water flushing: Rinse off the dust on the fins with clean water again
- Air conditioner special cleaning agent: choose special cleaning agent for air conditioner fins, evenly. Spray on the surface of the fin for more than 0.5h (determined by the thickness of the dust)
- If necessary, use a special brush for cleaning air conditioners to brush the fins (to prevent rewinding)
- Check whether there are water droplets on the electronic control components, and then turn on the power supply and start the operation after ensuring safety.

8-2 Clean water tank fouling

Water tank fouling is easy to affect water quality

- Be sure to fill the storage tank with water before turning on the power and starting the heat pump unit. Ensure that water flows cleanly without obstruction.

8-3 Check the anode and replace regularly

Check the anode and replace if necessary (frequency: every six months in poor water quality environments). Anodically protects the lining of the hot water tank. As the anode deteriorates, the degree of protection decreases. It is recommended to periodically check the anode for degradation and replace the anode if needed. Anode replacement is subject to the Australian Plumbing Code and advice from your plumber should be sort to ensure proper frequency of anode replacements over the life of the water heater.

- Turn off the heat pump unit (disconnect the power supply directly)
- turn off the stop valve ○1 and turn on the stop valve ○5 ; and faucet to drain the tank
- Locate the anode position and unscrew the anode cover
- Use an Allen wrench to loosen
- Check the consumption of the anode, if it is used up, it needs to be replaced immediately, so as not to affect the quality of the water
- To restore the state of use, be sure to fill up the water first and observe whether there is any leakage. Turn on the power, turn on the heat pump to heat the water to the termination temperature, and then observe whether there is any leakage here, before leaving.

8-4 PTR maintenance

Operate the valve (release PTR Valves every six months). Periodic operation of the valve is recommended to ensure smooth water flow. If the water does not flow freely, ensure all blockages are removed and change the PTR valve.

In order to avoid the expansion and deformation of the water tank due to excessive pressure, the service life of the water tank will be affected if a faulty PTR valve is not replaced.



- Check the correct position of the valve
- Carefully release the valve with the lever to release some water from the tank. Note: Please manage water discharged to avoid damage to other items from excessive water release.
- If the water is flowing, the valve is still in proper working order
- If the water does not flow freely, the valve is out of function and needs to be replaced

- If the valve needs to be replaced, please contact your plumber or our service team for further assistance

8-5 check

1. Please check the machine regularly for any damage, if there is obvious damage, please contact our maintenance team.
2. In some cold areas (below zero degrees Celsius), if the system stops working for a long time, all the water in the water tank should be released and re-installed in the water tank.

★8-6 Water quality requirements for water supply (chloride and pH)

1. In areas of water supplies with high chloride levels, water can corrode certain parts, causing them to fail.
2. This Heat Pump Water Heater is not suitable for operating if the chloride content exceeds 200 mg/l. pH is a measure of whether water is alkaline or acidic.
3. Heat pump units and hot water tank units with a Ph value less than 6.0 are not guaranteed.
4. The water supply to rainwater storage tanks within urban agglomerations can be corrosive due to the dissolution of atmospheric pollutants.
5. Water with a pH value of less than 6.0 can be treated to increase the pH value, so it is recommended to analyze the quality of tap water before connecting to this type of water supply system.

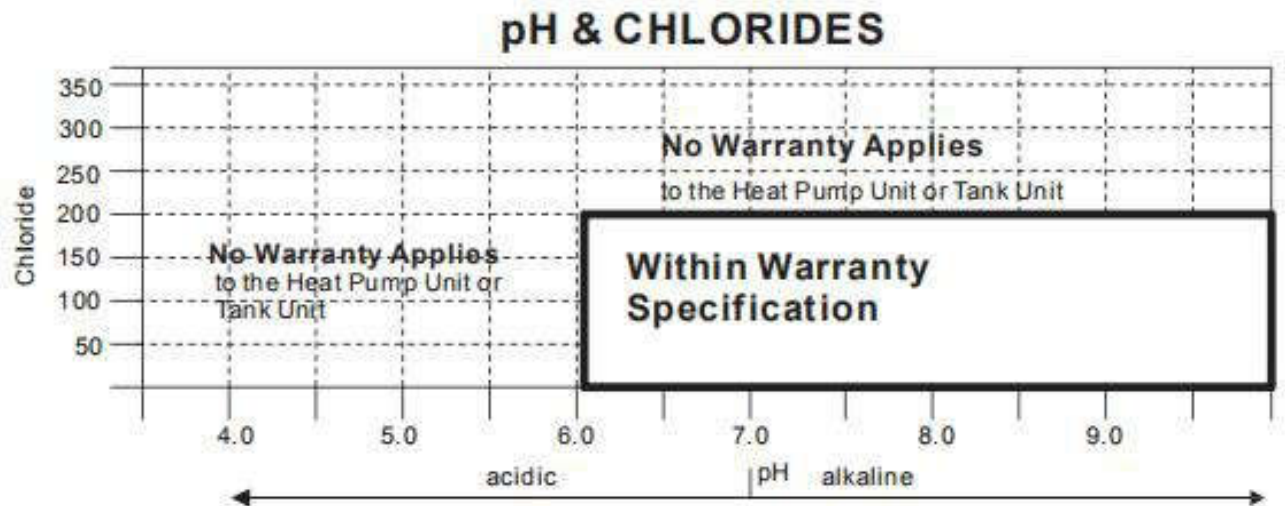

9||The warranty

9-1 Warranty Policy Warranty Conditions

The ECOGENICA Heat Pump Water Heater System must be installed in accordance with the installation instructions supplied with the Heat Pump Water Heater System, and in accordance with all relevant statutory/local requirements of the state/province/municipality in which the water heater is installed.

- 2) Where a failed component or Heat Pump Water Heater System is replaced under warranty, the balance of the original warranty period will remain effective. The replaced part or Heat Pump Water Heater System does not carry a new warranty.
- 3) Where the Heat pump Water Heater System is installed in a position that does not allow safe, ready access, the cost of accessing the site safely, including the cost of additional materials handling and/or safety equipment, shall be the owner's responsibility.
- 4) The warranty only applies to the Heat Pump Water Heater System and original or genuine (company) component replacement parts and therefore does not cover any plumbing or electrical parts supplied by the installer and not an integral part of the Heat Pump Water Heater System. Such parts would include pressure regulating valve, isolation valves, check valves, electrical switches, pumps or fuses.
- 5) The Heat pump Water Heater System must be sized to supply the hot water demand in accordance with the guidelines in the ECOGENICA Heat Pump Water Heater System Literature.
- 6) This warranty is for parts only, any and all labor costs associated with diagnosis, removal of the faulty part and installation of replacement parts will solely be the owner's responsibility.

Warranty Exclusions

Repair and replacement work will be carried out as set out in the ECOGENICA Heat Pump Water Heater System warranty. However the following exclusions may void the warranty and may incur additional service charges and/or cost of parts.

- 2) Accidental damage to the Heat Pump Water Heater System or any component, including: Acts of God, failure due to misuse, incorrect installation, attempts to repair the water heater other than by a ECOGENICA accredited service agent or the ECOGENICA service department.
- 3) Where it is found there is nothing wrong with the Heat Pump Water Heater System; where the complaint is related to excessive discharge from the temperature and/or the pressure relief valve due to high water pressure; where there is no flow. If hot water due to faulty plumbing; where water leaked are related to plumbing and not the Heat Pump Water Heater System or its components; where there is a failure of electricity or water supplies; where the supply of electricity or water does not comply with relevant codes or acts.
- 4) Where the Heat Pump Water Heater System or its component has failed directly or indirectly as a result of excessive water pressure.
- 5) Overflow vent drain has not been installed or blocked or corroded.
- 6) Where the Heat Pump has rusted as a result of a corrosive atmosphere.
- 7) Where the unit fails to operate or fails as a result of ice formation in the piping to or from the Heat Pump Water Heater System.
- 8) Where the Heat Pump Water Heater System is located in a position that does not comply with the Heat Pump Water Heater System installation instructions, or relevant statutes. requirements, causing the need for major dismantling or removal of cupboards, doors or walls, or use of special equipment to bring the Heat Pump Water Heater System to floor or ground level or to a serviceable position.
- 9) Repair and/or replacement of the Heat Pump Water Heater System due to scale formation above 200ppm (water hardness) in the waterways or the effects of either corrosive water or water with a high chloride or low PH level when the water heater has been

connected to a scaling or corrosive water supply or a water supply with a high chloride or low PH level as outlined in the Owner's Guide and installation Manual.

10) Warranty service is provided to the original owner of the equipment only. Subject to any statutory provisions to the contrary, this warranty excludes any and all claims for damage to furniture, carpets, walls, foundations or any other consequential loss either directly or indirectly due to leakage from the Heat Pump Water Heater System, or due to leakage from fittings and/or pipe work of metal, plastic or other materials caused by water temperature, poor Workmanship or other modes of failure.

9-2 Warranty Period

Subject to the Warranty Conditions and Exclusions stated above, your ECOGENICA Heat Pump Water Heater System is warranted in a Residential application as follows:

Heat pump unit – ECOGENICA warrants all parts labour on the ECOGENICA water heater system for a period of 7 years from date of installation.

Labour costs are paid directly to the servicing contractor per the payment cost schedule published by ECOGENICA and revised from time to time at ECOGENICA requirement.

Tank unit – ECOGENICA warrants that the tank will be free from defects for 7 years at 100% replacement, and for a further 1 years under a pro-rated scale, culminating in warranty end after 6 years from date of installation.

In a Commercial or industrial application the warranty period on both Heat Pump unit and Tank is reduced to 1 year only with no Labour warranty

ECOGENICA Contact Details

6 Braeside Drive, Braeside VIC 3195

p 1300 341 010

w ecogenica.com.au

w ecoalliance.com.au