



Installation & Owners Manual



Midea Split Heat Pump Water Heater
200 Litre / 300 Litre

CONTENTS

1	SAFETY PRECAUTIONS	01
2	GENERAL INTRODUCTION	
	• 2.1 Outdoor unit	05
	• 2.2 Water tank	05
	• 2.3 Specifications	06
3	BEFORE INSTALLATION	
	• 3.1 Accessories	07
	• 3.2 Space for maintenance	07
4	INSTALLATION PROCEDURE	
	• 4.1 Dimension sketch and fixed way	09
	• 4.2 Drain hole position	10
	• 4.3 Pipe connection	11
	• 4.4 Vacuum drying	13
	• 4.5 Refrigerant charge	14
5	ELECTRICAL CONNECTION	
	• 5.1 Power supply cords	15
	• 5.2 Water tank temperature sensor installation	16
	• 5.3 ODU & AUX. power connection	16
	• 5.4 Dial code definitions	17
6	CHECK	18
7	OPERATIONS AND PERFORMANCES	19
8	MAINTENANCE	
	• 8.1 Confirmation before running	20
	• 8.2 Troubleshooting when abnormal situation happens	20
	• 8.3 After-sale service	20
	• 8.4 Important information for the used refrigerant	20
	• 8.5 Water quality limitations	21
9	ERROR CODE SHOOTING TABLE	22
10	WARRANTY	23

1 SAFETY PRECAUTIONS

The precautions listed here are divided into the following types. They are important, so be sure to follow them carefully.

Meanings of DANGER, WARNING, CAUTION and NOTE symbols.

INFORMATION

- Read these instructions carefully before installation. Keep this manual in a handy for future reference.
- Improper installation of equipment or accessories may result in electric shock, short-circuit, leakage, fire or other damage to the equipment. Be sure to only use accessories made by the supplier, which are specifically designed for the equipment and make sure to get installation done by a professional.
- All the activities described in this manual must be carried out by a licensed technician. Be sure to wear adequate personal protection equipment such as gloves and safety glasses while installing the unit or carrying out maintenance activities.
- Contact your dealer for any further assistance.

DANGER

Indicates an imminently hazardous situation which if not avoided, will result in death or serious injury.

WARNING

Indicates a potentially hazardous situation which if not avoided, could result in death or serious injury.



CAUTION

Indicates a potentially hazardous situation which if not avoided, may result in minor or moderate injury. It is also used to alert against unsafe practices.

NOTE

Indicates situations that could only result in accidental equipment or property damage.

Explanation of symbols displayed on the unit

	CAUTION	This symbol shows that the operation manual should be read carefully.
	CAUTION	This symbol shows that a service personnel should be handling this equipment with reference to the installation manual.
	CAUTION	This symbol shows that information is available such as the operating manual or installation manual.

WARNING

For continued safety of this appliance it must be installed, operated and maintained in accordance with the manufacturer's instructions.

WARNING

This appliance may deliver water at high temperature. Refer to the Plumbing Code of Australia (PCA), local requirements and installation instructions to determine if additional delivery temperature control is required.

DANGER

- The operation of the thermal cut-out indicates a possibly dangerous situation. Do not reset the thermal cut-out until the water heater has been serviced by a qualified person.
- Failure to operate the relief valve easing gear at least once every six months may result in the water heater exploding. Continuous leakage of water from the valve may indicate a problem with the water heater.
- If the hot water system is not used for two weeks or more, a quantity of highly flammable hydrogen gas may accumulate in the water heater. To dissipate this gas safely, it is recommended that a hot tap be turned on for several minutes or until discharge of gas ceases. Use a sink, basin, or bath outlet, but not a dishwasher, clothes washer, or other appliance. During this procedure, there must be no smoking, open flame, or any electrical appliance operating nearby. If hydrogen is discharged through the tap, it will probably make an unusual sound as with air escaping.
- Before touching electric terminal parts, turn off power switch.
- Do not touch the inner parts of the controller. Do not remove the front panel. Some parts inside are dangerous to touch, otherwise a machine malfunction may be caused.
- When front panels are removed, live parts can be easily touched by accident.
- Never leave the unit unattended during installation or servicing when the front panel is removed.
- Do not touch water pipes during and immediately after operation as the pipes may be hot and could burn your hands. To avoid injury, give the piping time to return to normal temperature or be sure to wear protective gloves.
- Do not touch any switch with wet fingers. Touching a switch with wet fingers can cause electrical shock.
- Before touching electrical parts, turn off all applicable power to the unit.

WARNING

- If the water supply pressure exceeds the rated pressure, a pressure reducing valve is to be fitted in the installation.
- The water may drip from the discharge pipe of the pressure-relief device and that this pipe must be left open to the atmosphere.
- The pressure-relief device is to be operated regularly to remove lime deposits and to verify that it is not blocked.
- A discharge pipe connected to the pressure-relief device is to be installed in a continuously downward direction and in a frost-free environment.
- For appliances with supplementary heaters, the minimum clearance from the appliance to combustible surfaces will be 3m.
- The installation of the appliance shall conform to the Plumbing Code of Australia (PCA).
- A suitable breaker / RCBO must be installed on the electrical circuit.
- Do not remove, cover or deface any permanent instructions, labels, or the data labels from either the outside of the unit or inside of unit panels.
- Requires qualified person for relocating, repairing and maintaining the unit.
- Electric connection work should obey the instructions of local power company, local electric utility and this manual.
- Never use the wiring and fuse with wrong rated current, otherwise the unit may break down and cause a fire.
- Do not insert fingers, rods or other objects into the air inlet or outlet. When the fan is rotating at high speed, it will cause injury.
- Never use a flammable spray such as hair spray, lacquer paint near the unit. It may cause a fire.
- This appliance is not intended for use by persons (including children) with reduced physical, sensory or mental capabilities or lack of experience and knowledge, unless they have been given supervision or instruction concerning use of the appliance by a person responsible for their safety. Children should be supervised to ensure that they do not play with the appliance.
- Tear apart and throw away plastic packaging bags so that children will not play with them. Children playing with plastic bags face danger of death by suffocation.
- Safely dispose of packing materials such as nails and other metal or wood parts that could cause injuries.
- Ask your dealer or qualified personnel to perform installation work in accordance with this manual. Do not install the unit yourself. Improper installation could result in water leakage, electric shocks or fire.
- Be sure to use only specified accessories and parts for installation work. Failure to use specified parts may result in water leakage, electric shocks, fire, or the unit falling from its mount.
- Install the unit on a foundation that can withstand its full weight. Failure to do so may cause the equipment to fall and result in possible damage or injury.
- Perform specified installation work with full consideration of strong wind, hurricanes, or earthquakes. Improper installation work may result in accidents due to equipment falling.

- Make certain that all electrical work is carried out by qualified personnel according to the local laws and regulations and this manual. Electrical circuit must be able to hold the load. Insufficient capacity of the power supply circuit or improper electrical construction may lead to electric shocks or fire.
- Be sure to install a ground fault circuit interrupter according to local laws and regulations. Failure to install a ground fault circuit interrupter may cause electric shocks and fire.
- Make sure all wiring is secure. Use the specified wires and ensure that terminal connections or wires are protected from water and other adverse external forces. Incomplete connection or affixing may cause a fire.
- When wiring the power supply, form the wires so that the front panel can be securely fastened. If the front panel is not in place there could be overheating of the terminals, electric shocks or fire.
- After completing the installation work, check to make sure that there is no refrigerant leakage.
- Never directly touch any leaking refrigerant as it could cause severe frostbite. Do not touch the refrigerant pipes during and immediately after operation as the refrigerant pipes may be hot or cold, depending on the condition of the refrigerant flowing through the refrigerant piping, compressor and other refrigerant cycle parts. Burns or frostbite are possible if you touch the refrigerant pipes. To avoid injury, give the pipes time to return to normal temperature or, if you must touch them, be sure to wear protective gloves.
- Do not touch the internal parts (pump, backup heater, etc.) during and immediately after operation. Touching the internal parts can cause burns. To avoid injury, give the internal parts time to return to normal temperature or, if you must touch them, be sure to wear protective gloves.
- Servicing shall only be performed as recommended by the equipment manufacturer. Maintenance and repair requiring the assistance of other skilled personnel shall be carried out under the supervision of the person competent in the use of flammable refrigerants.

CAUTION

- The earthing pole of socket must be grounded well, make sure that power supply socket and plug are dry enough and connected tightly.
- Before cleaning, be sure to stop the unit and turn the breaker off or pull out the power plug.
- After a long term use, check the unit base and fittings. If damaged, the unit may sink and result in injury.
- Arrange the drain pipe to ensure smooth draining.
- Do not turn off the power supply. System will stop or restart heating automatically. A continuous power supply for water heating is necessary, except service and maintenance.
- Ground the unit.
- Grounding resistance should be according to local laws and regulations.
- Do not connect the ground wire to gas or water pipes, lightning conductors or telephone ground wires. Incomplete grounding may cause electric shocks.
 - Gas pipes: Fire or an explosion might occur if the gas leaks.
 - Water pipes: Hard vinyl tubes are not effective grounds.
 - Lightning conductors or telephone ground wires: Electrical threshold may rise abnormally if struck by a lightning bolt.
- Do not wash the unit. This may cause electric shocks or fire. The appliance must be installed in accordance with national wiring regulations. If the supply cord is damaged, it must be replaced by the manufacturer, its service agent or similarly qualified persons in order to avoid a hazard.
- Do not install the unit in the following places:
 - Where there is mist of mineral oil, oil spray (eg: kitchen) or vapors. Plastic parts may deteriorate, and cause them to come loose or water to leak.
 - Where corrosive gases (such as sulphurous acid gas) are produced. Where corrosion of copper pipes or soldered parts may cause refrigerant to leak.
 - Where there is machinery which emits electromagnetic waves. Electromagnetic waves can disturb the control system and cause equipment malfunction.
 - Where flammable gases may leak, where carbon fiber or ignitable dust is suspended in the air or where volatile flammables such as paint thinner or gasoline are handled. These types of gases might cause a fire.
 - In vehicles or vessels.
 - Where acidic or alkaline vapors are present.
 - Other special environments.

- This appliance can be used by children 8 years old and above and persons with reduced physical, sensory or mental capabilities or lack of experience and knowledge if they are supervised or given instruction on using the unit in a safe manner and understand the hazards involved. Children should not play with the unit. Cleaning and user maintenance should not be done by children without supervision.
- Children should be supervised to ensure that they do not play with the appliance.
- If the supply cord is damaged, it must be replaced by the manufacturer or its service agent or a similarly qualified person.
- DISPOSAL: Do not dispose this product as unsorted municipal waste. Collection of such waste separately for special treatment is necessary. Do not dispose of electrical appliances as municipal waste, use separate collection facilities. Contact your local government for information regarding the collection systems available. If electrical appliances are disposed of in landfills or dumps, hazardous substance can leak into the groundwater and get into the food chain, damaging your health and well-being.
- The wiring must be performed by professional technicians in accordance with national wiring regulation and this circuit diagram. An all-pole disconnection device which has at least 3mm separation distance in all pole and a residual current device(RCD) with the rating not exceeding 30mA shall be incorporated in the fixed wiring according to the national rule.
- Confirm the safety of the installation area (walls, floors, etc.) without hidden dangers such as water, electricity, and gas.
- Before installation, check whether the user's power supply meets the electrical installation requirements of unit (including reliable grounding, leakage, and wire diameter electrical load, etc.). If the electrical installation requirements of the product are not met, the installation of the product is prohibited until the product is rectified.
- When installing multiple air conditioners in a centralised manner, please confirm the load balance of the three-phase power supply, and multiple units are prevented from being assembled into the same phase of the three-phase power supply.
- Product installation should be fixed firmly. Take reinforcement measures, when necessary.

NOTE

- The appliance is intended to be permanently connected to the water mains and not connected by a hose-set.
 - When using the off-peak function, the product can only work under the off-peak power supply all the time.
- About Fluorinated Gasses
- This air-conditioning unit contains fluorinated gasses. For specific information on the type of gas and the amount, please refer to the relevant label on the unit itself. Compliance with national gas regulations shall be observed.
 - Installation, service, maintenance and repair of this unit must be performed by a certified technician.
 - Product un-installation and recycling must be performed by a certified technician.

CAUTION

- Generally, the ambient air temperature of the unit must be above -15°C and below 43°C.
- Install safety valve to water inlet, the largest torque of safety valve shouldn't be more than 80N.m.
- Please make sure the water tank is installed upright. Install in the place that can prevent unit toppling and falling (e.g. balcony or corner). If installing unit in an open space, to avoid being blown down by strong wind (especially in an area with strong wind), please fix water tank according to operation manual.
- All the diagrams in this manual is for reference only, its appearance and function may different from actual water heater. Actual model shall prevail.

2 GENERAL INTRODUCTION

2.1 Outdoor unit

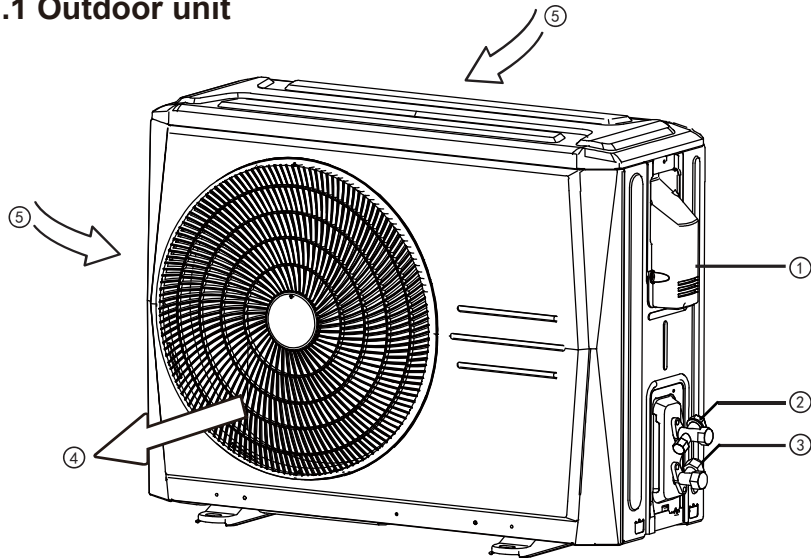

Table 2-1

No.	Name
①	Power cord enter
②	Refrigerant gas valve
③	Refrigerant liquid valve
④	Air outlet
⑤	Air inlet

Fig. 2-1

2.2 Water tank

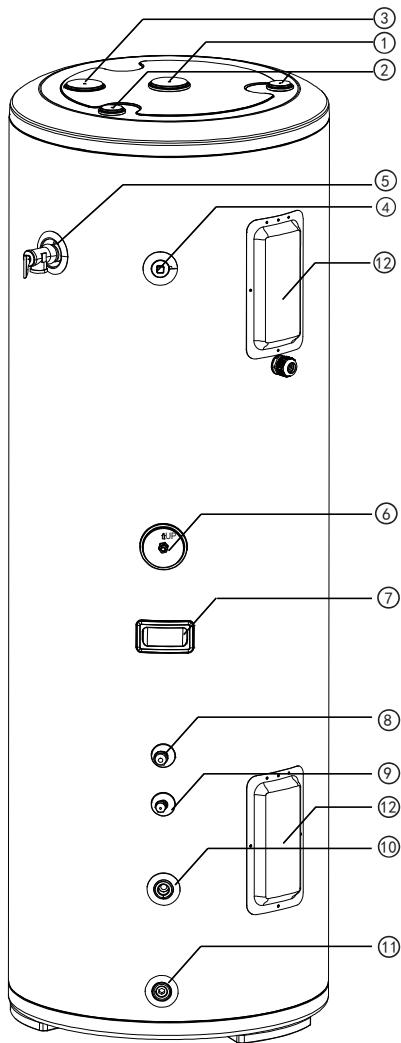

Table 2-2

No.	Name
①	Magnesium rod insertion port
②	Foam filling port
③	Reserved port
④	Water outlet
⑤	Temperature pressure safety valve
⑥	Water tank temperature sensor
⑦	Handle
⑧	Refrigerant gas pipe
⑨	Refrigerant liquid pipe
⑩	Water inlet
⑪	Drain outlet
⑫	Electric auxiliary heater

Fig. 2-2

300L With Aux.*

2.3 Specifications

Table 2-3

General	Model No. Residential (Outdoor / indoor)		MHW-F26WN3/MT-200R26E20	MHW-F26WN3/MT-300R26E20		
	Model No. Commercial (Outdoor / indoor) [^]		MHW-F26WN3-C/MT-200R26E20	MHW-F26WN3-C/MT-300R26E20		
	Ambient temperature		°C	-15~46		
	Leaving water temperature		°C	20~60		
	Heating	Capacity ¹	W	2600		
		Input	W	1000		
	Hot water yield		m ³ /h	0.0441 ¹ / 0.0562 ²		
	Refrigerant piping	Liquid side	mm/inch	φ6.35 / φ1/4'		
		Gas side	mm/inch	φ9.52 / φ3/8'		
		Max. height difference	m	10		
Max. refrigerant pipe length		m	20			
Design pressure		MPa	3			
Outdoor unit	Outdoor unit power supply		V/N/Hz	220-240/1/50		
	Max. current		A	8.7	8.7	
	Compressor Type		Type	Rotary		
	Fan	Type		AC		
	Air side heat exchanger		Type	Hydraulic aluminum fin + Inner grooved copper tube		
	Throttle		Type	Electric expansion valve		
	Outdoor sound pressure level		dB(A)	54		
	Dimension	Unit dimension(L*W*H)		mm	804*327*555	
		Packing dimension(L*W*H)		mm	845*390*630	
		Net weight		kg	29	
		Gross weight		kg	32	
	Refrigerant	Type		R134a		
		Charged volume		g	900	
Water Tank	Tank volume		L	200	300	
	Electric heater	Capacity	kW	1	1	
		Power supply	V/N/Hz	220-240/1/50	220-240/1/50	
	Dimension	Unit dimension(W*D*H)		mm	505*505*1665	580*580*1735
		Packing dimension(W*D*H)		mm	1775*635*590	1835*690*670
		Net weight		kg	73	96
Gross weight		kg	83	108		

Notes:

[^] Dial Code (dip switch) S2-1 must be set to position '1' (Reserve) for commercial applications. Refer to page 17.

1. Ambient temperature 19/15°C(DB/WB), Initial water temperature 9°C, Terminative water temp. 60°C.

2. Ambient temperature 19/15°C(DB/WB), Initial water temperature 15°C, Terminative water temp. 55°C.

Unit: °C

Table 2-4

Ambient temperature	Leaving water temperature
-15~-10	50
-10~43	60
43~46	55



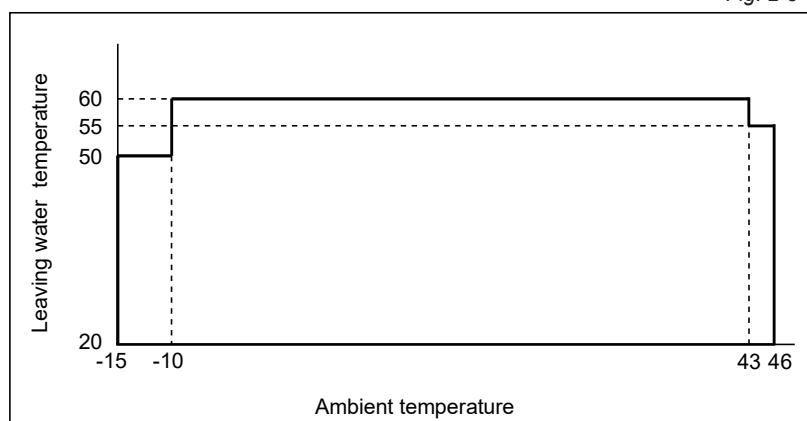





Fig. 2-3



3 BEFORE INSTALLATION

3.1 Accessories

Table 3-1

Accessory Name	Qty.	Shape	Purpose
Outdoor unit	1		Need by master unit
	1		Wired controller instructions
	1		Control unit and display unit status
	1		For condensate water draining
	1	—	Condensate water drainage of unit bottom plate
	4	—	To fix mounting box
	4	—	To fix mounting box
	1		Install the wired controller
	1	—	Connect the unit and HMI
Water tank	1		Fixed water tank
	1		Pressure relief
	1		Prevents backflow of water
	2		Connect the safety valve and the water tank
	1	—	Drain water from tank when necessary

3.2 Space for maintenance

NOTE

During installing, it is necessary to reserve enough installation space and maintenance space according to the following figures.

3.2.1 Outdoor unit installation and maintenance space, see Fig 3-1 and Fig 3-2. (Unit: mm)

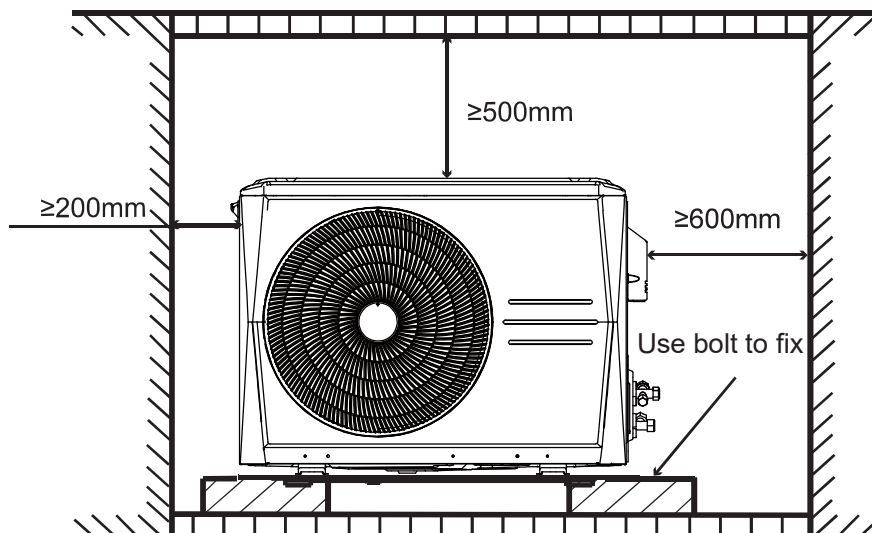

Fig 3-1

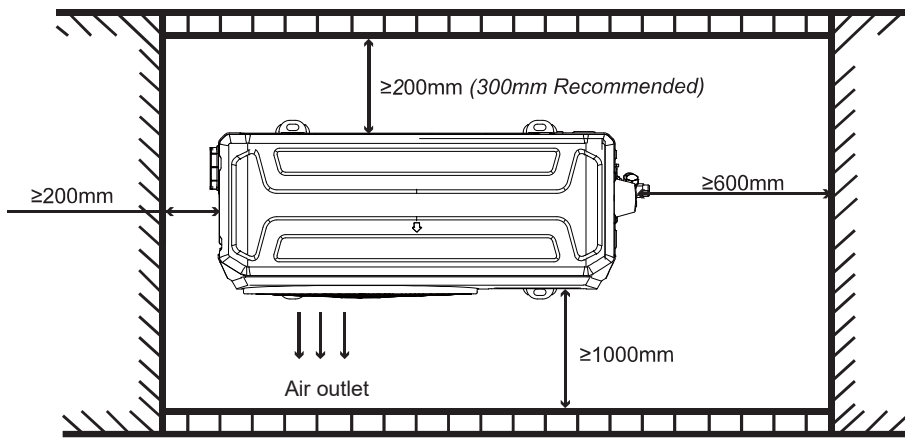

Fig 3-2

3.2.2 Water tank installation and maintenance space, see Fig 3-3 and Fig 3-4 . (Unit: mm)

NOTE

- It is recommended that when the water tank is installed outdoors, the distance between the water tank and the fence is not less than 200mm.
- It is recommended that when the water tank is installed indoors, the distance between the water tank and the wall is not less than 600mm.

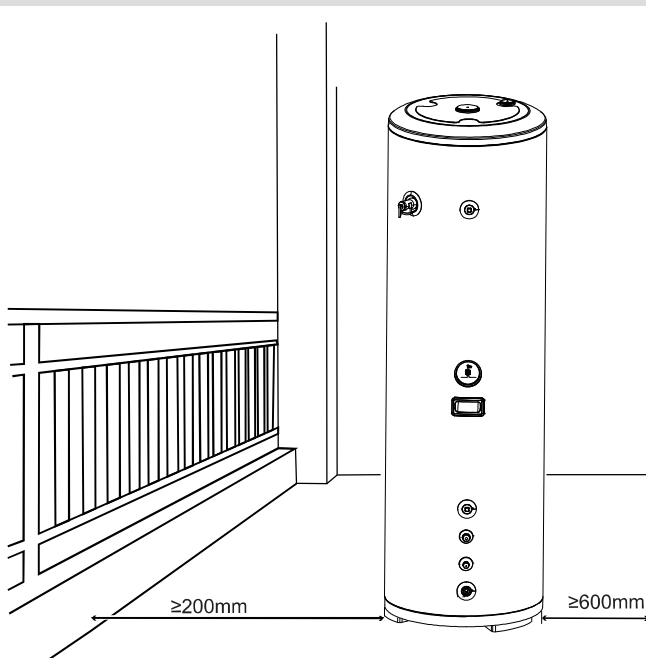

Fig 3-3

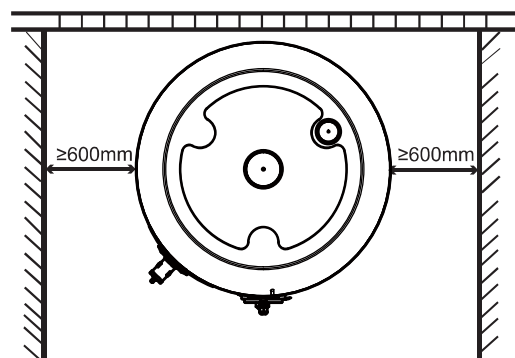

Fig 3-4

4 INSTALLATION PROCEDURE

NOTE

- Ask your dealer or specialised person for moving, repair and maintenance.
- The substrate must be horizontal, and its structure must endure the full weight of the unit.
- Please firmly install the unit, otherwise it may cause abnormal noise and vibration.
- Remove obstacles nearby, a narrow circulation space may influence performance of the unit.
- Install in the place that closest to water tank as possible, under the condition that the installation requirements could be satisfied.
- When installing in the place that near to the sea and high place where strong wind blows, install the unit against a wall or use a baffle when necessary to ensure the unit could run normally, see Fig 4-1. Especially in the place with strong wind, pay attention not to let strong wind blow back to the unit.
- If install the unit in a basement, inside the room or other confined space, please pay attention to air discharge and air supply circulation around the unit and outside. Circulation air volume should not less than 1250m³/h.

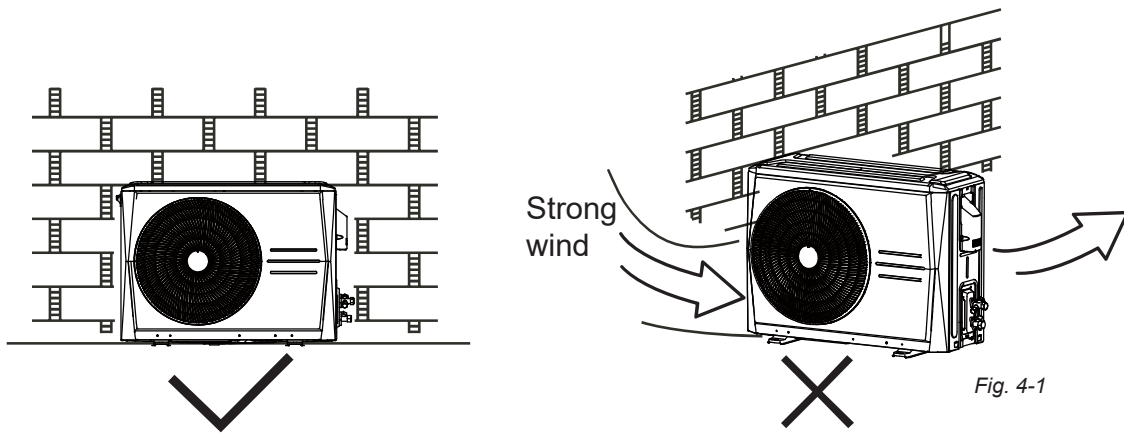

Fig. 4-1

4.1 Product Dimensions

4.1.1 Outdoor unit, see Fig. 4-2, Fig. 4-3 and Table 4-1. (Unit: mm)

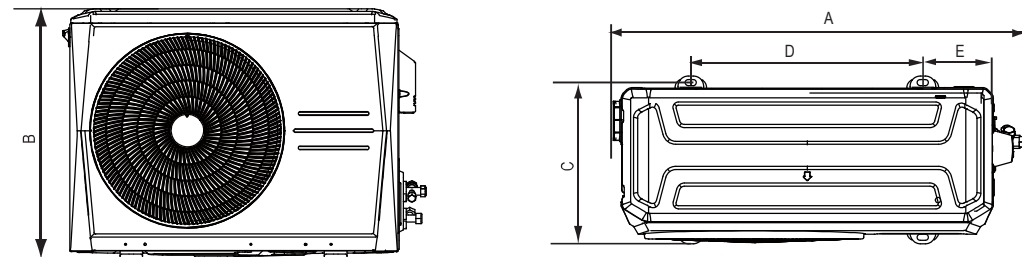

Fig. 4-2

Please fix the four bases of the outdoor unit on the flat ground with bolts.

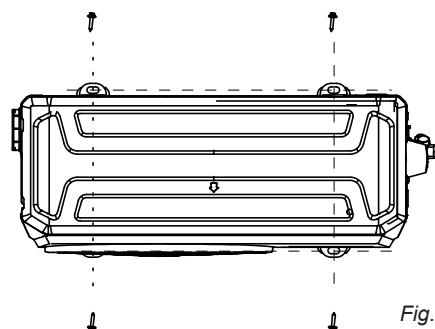

Fig. 4-3

Table 4-1

Dimensions				
A	B	C	D	E
804	555	302	452	137

4.1.2 Water tank, see Fig. 4-4, Fig. 4-5 and Table 4-2. (Unit: mm)

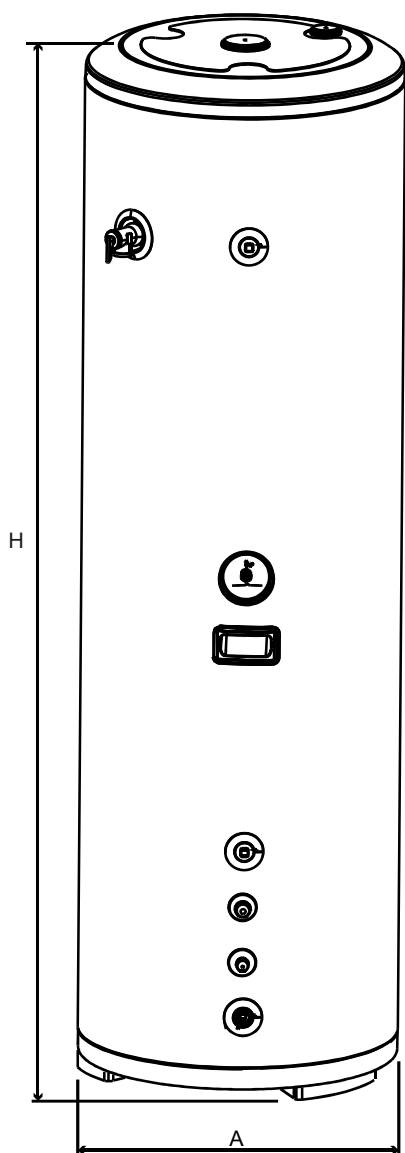
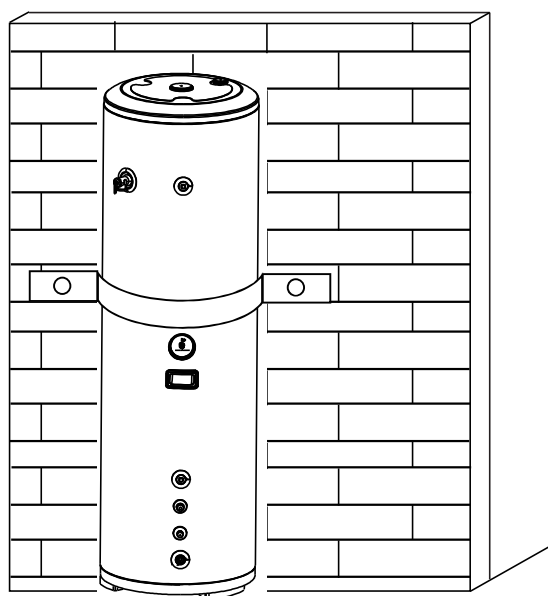

Table 4-2

Dimension Model	A	H
200L	505	1665
300L	580	1735



Where necessary the tank can be fixed to the adjoining substrate using the supplied tank fixing strap.

Fig. 4-4

Fig. 4-5

4.2 Drain hole position

Water outlet
connection
pipe/ Gasket

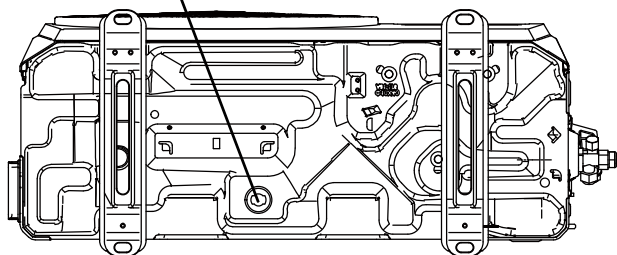

Fig 4-6

Please use the Allen wrench to open the drain valve to drain the water. If no water flows out, it means that the draining is completed.

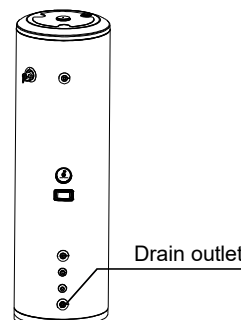

Fig 4-7

4.3 Pipe connection

4.3.1 Unit connection diagram

Unit connection diagram, please refer to Fig.4-8.

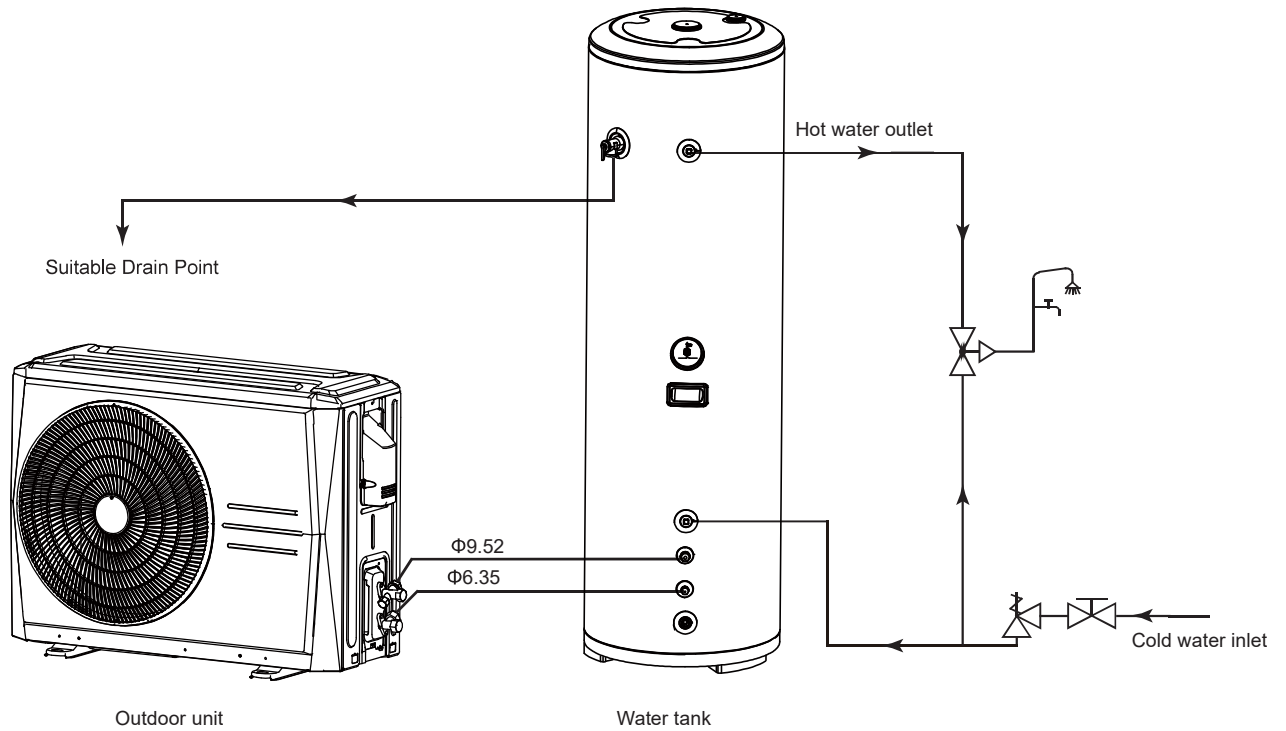

Fig. 4-8

Icons and meanings

Table 4-3

Name	Water end user	Stop valve	Water mixing temp. valve	Pressure limiting valve (where required)
Icon				

NOTE

- The water tank temperature can be set from 20 °C to 60 °C.
- The minimum water inlet pressure is not less than 150kPa, and the maximum is not more than 650kPa. If the inlet water pressure is less than 150kPa, a pump should be installed at the water inlet.
- To guarantee the safety usage of tank, a pressure limiting valve should be installed in the water inlet pipe, if the water pressure exceeds 650kPa.
- It is strongly recommended to use thread seal tape for sealing when connecting water pipes and valves.

4.3.2 PTR valve

- The valve body unloading pressure is 850kPa, unloading temperature is 99°C, and the valve body opening energy value is 46kJ, more details refer to certificate No:WMK26608.
- PTR valve is tightened with a 68N.m torque wrench. Apply sealant to the first 3 turns of screw thread before installation; After installation, the outlet of the drain pipe shall be installed face down, and the thread turns that are not screwed into the PTR valve shall be less than 3 turns.
- Before filling the water tank, the PTR valve must be installed properly.
- The PTR valve should be checked every half year to make sure that there is no restriction of the valve. Please beware of hot water from the valve. The drainage pipe should be well insulated in order to prevent water inside pipe from freezing in cold weather.
- The PTR drain piping must match the output size of the PTR valve (i.e 3/4" output, requires 3/4" piping)

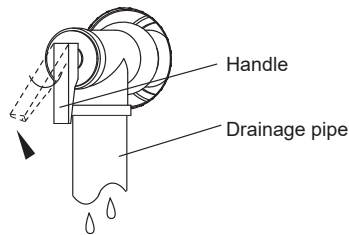

Fig.4-9

4.3.3 Stop valve instruction

- In general, the shape of stop valve and names of each part are shown in Fig.4-10.
- Effect of stop valve:
 - Stop the system when the unit is working.
 - When water tank connects with the outdoor unit, vacuumise and add refrigerant through it.
 - Stop the system and then recycle refrigerant to outdoor unit when maintaining.
- Open and close the stop valve:
 - Open: dismantle the bonnet by wrench and insert an *Allen key to spool, open the stop block anticlockwise and then tighten the bonnet.
 - Close: use a wrench to dismantle the bonnet and insert an Allen key to spool, close the stop block clockwise and then tighten the bonnet.

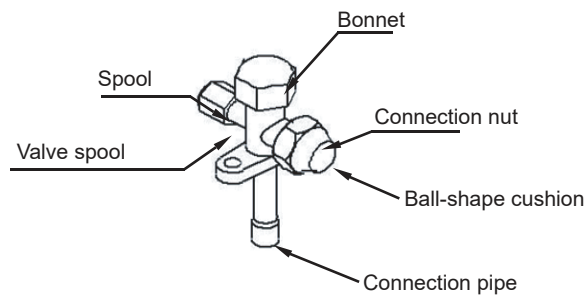
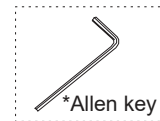

Fig.4-10

⚠ CAUTION

Before water heater runs, please make sure every stop valve has been opened.

4.3.4 Connection length of outdoor unit and water tank pipe and height difference requirements:

Table 4-4

Max.length (m)	Max. height difference (m)
20	10

Additional refrigerant is required where length exceeds 10m (refer to section 4.5)

NOTE

- Do not let air, dust, or other impurities fall in the pipe system during installation.
- The connecting pipe should not be installed until the indoor and outdoor units have been fixed already.
- Keep the connecting pipe dry, and do not let moisture in during installation.
- When connecting copper pipe, please wrap it with thermal insulation material.

4.4 Vacuum Drying

4.4.1 Purpose

Vacuum drying should be performed in order to remove moisture and non-condensable gases from the system. Removing moisture prevents ice formation and oxidization of copper piping or other internal components. The presence of ice particles in the system would cause abnormal operation, whilst particles of oxidized copper can cause compressor damage. The presence of non-condensable gases in the system would lead to pressure fluctuations and poor heat exchange performance.

4.4.2 Procedure

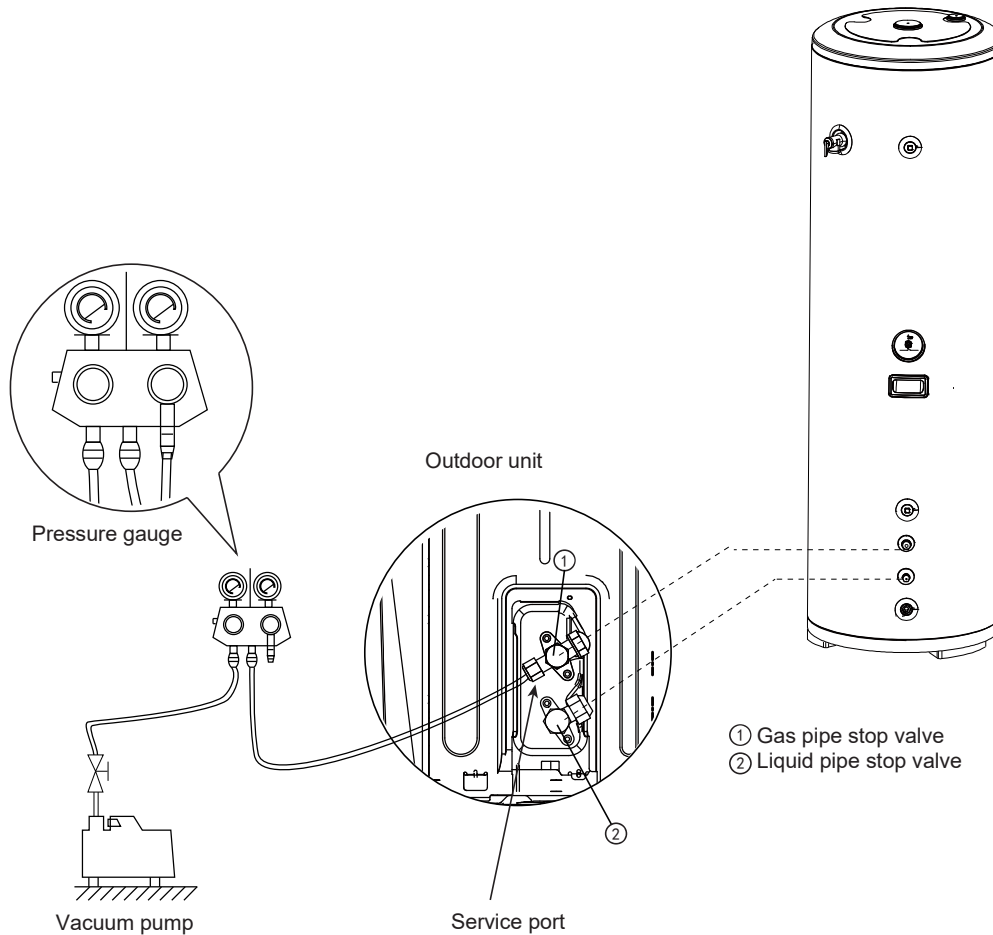
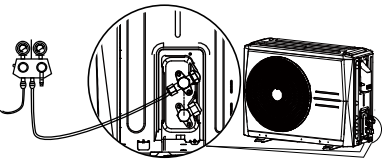
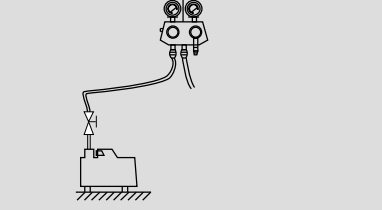
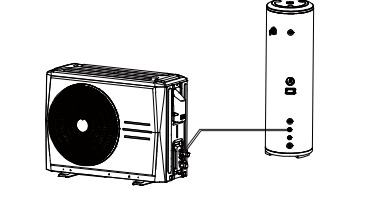
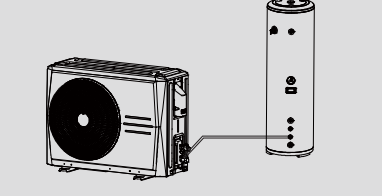

Fig.4-11

Item	Description	Image	Notice
1	Connect the (low pressure side) hose of a pressure gauge to the outdoor unit gas pipe stop valve.		Before performing vacuum drying, make sure that all the outdoor unit stop valves are firmly closed.
2	Connect the hose to the vacuum pump.		<p>1. Mixing of pump lubricant with compressor oil could cause compressor malfunction and a one-way valve should therefore be used to prevent vacuum pump lubricant seeping into the piping system.</p> <p>2. Using a vacuum pump with a discharge in excess of 4L/s and a precision level of 0.02mmHg is recommended.</p>
3	Connect the outdoor unit gas pipe stop valve to water tank gas pipe		
4	Connect the outdoor unit liquid pipe stop valve to water tank liquid pipe		
5	Start the vacuum pump and then open the pressure gauge valves to start vacuuming the system.		
6	<p>Once the gauges reach a pressure difference of at least -756mmHg (-100kPa) close the gauge.</p> <p>Continue monitoring to ensure the pressure difference remains at -756mmHg (-100kPa)</p> <p>If the pressure in the piping has not increased, the procedure is finished. If the pressure has increased, check for leakages and repeat process as necessary until the required pressure difference reaches the nominated value.</p>		After vacuum drying, keep the hoses connected to the pressure gauge and to the outdoor unit stop valves, in preparation for refrigerant charging.

4.5 Refrigerant charge

- Pipe length is 2~20m.
- If the pipe length is less than 10m, there is no need to add additional refrigerant charge.
- If the pipe length is more than 10m, adding additional refrigerant charge is necessary, and the rule is 20g/m for the additional pipe.

5 ELECTRICAL CONNECTION

CAUTION

- The heat pump should use a power supply with rated voltage, suitable to hold the load. If voltage is not stable, please use stabilised voltage supply.
- The external power supply to the heat pump should have ground wiring, which is linked to the ground wiring of the condenser and tank units.
- The wiring work should be done by qualified persons according to circuit drawing.
- A leakage protector should be installed according to the National Standard concerning electrical appliance.
- An all-pole disconnection device which has at least 3mm separation distance in contact points should be installed.
- Power supply cords and signal wires should be arranged properly. Separate strong current wire and weak current wire, meanwhile they can't contact with connection pipe and valve.
- Power supply with a leakage protector should be installed in a water-proof place inside the room.
- Don't do cross connection between 2 wires and signal wires must be shielded.
- When power supply cord parallels with controlling wire, please put the wires to corresponding wire pipe and leave proper space between wires.
- When selecting power supply cords, please refer to to the National Standard and this manual, power supply used outdoor should not be lighter than NO.57 wire in IEC 60245.
- If power supply cord is damaged, to avoid danger, it must be replaced by professional person.
- Do not turn on the power until you have checked carefully after wiring.

5.1 Power supply

5.1.1 Specification of power supply

Table 5-1

Model	Item	Power	Manual switch(A)		RCBO Leakage protector	Max. E-heater Power(W)
			Capacity	Fuse		
1kW Element (standard)		220-240V ~50Hz	15	10	30mA below 0.1 sec	1000
2kW Element (optional)			20	15		2000

5.2 Water tank temperature sensor installation

Connect the water tank temperature sensor wire connector to the outdoor unit T5L connector.

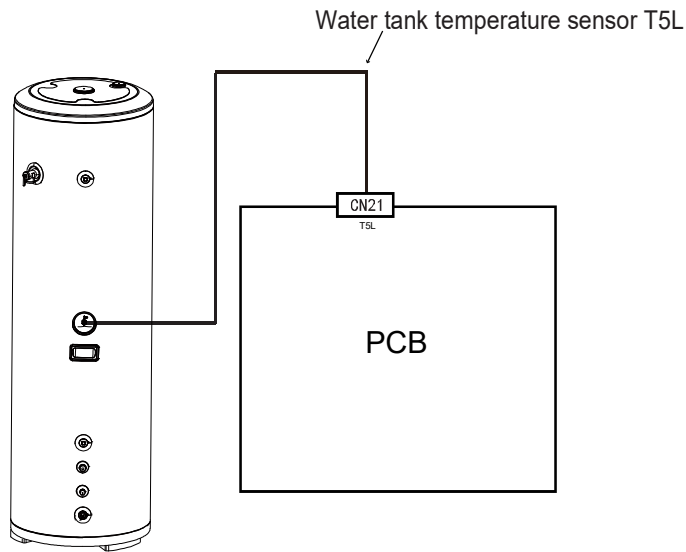

Fig.5-1

5.3 Tank & Auxiliary (AUX) power connection

NOTE

If the water tank has the electric auxiliary heating (AUX) function, please follow the steps below to connect the electric auxiliary heating power cord.

1. Remove the protective cover of the electric control box on the right side of the outdoor unit.

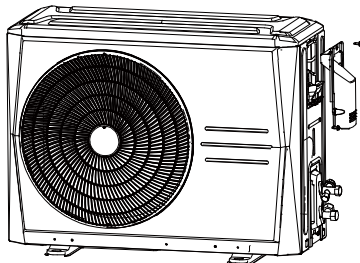

Fig.5-2

2. Connect the electric auxiliary heating power line on the water tank to the corresponding port on the terminal block.

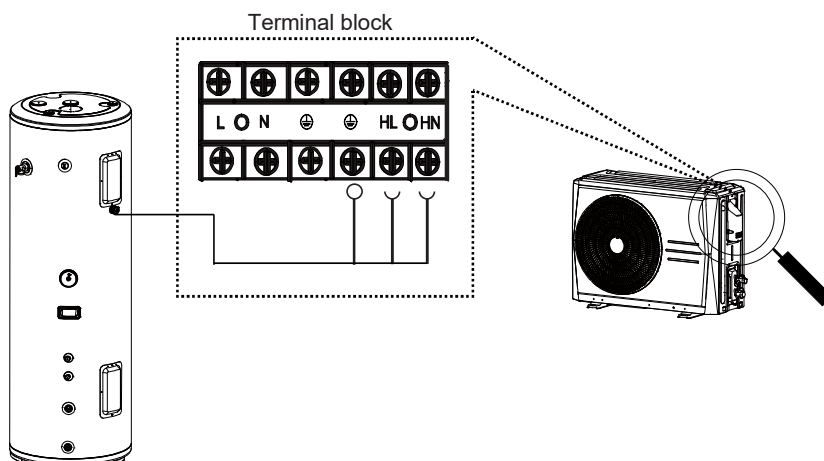

Fig.5-3

3. Outdoor unit power supply.

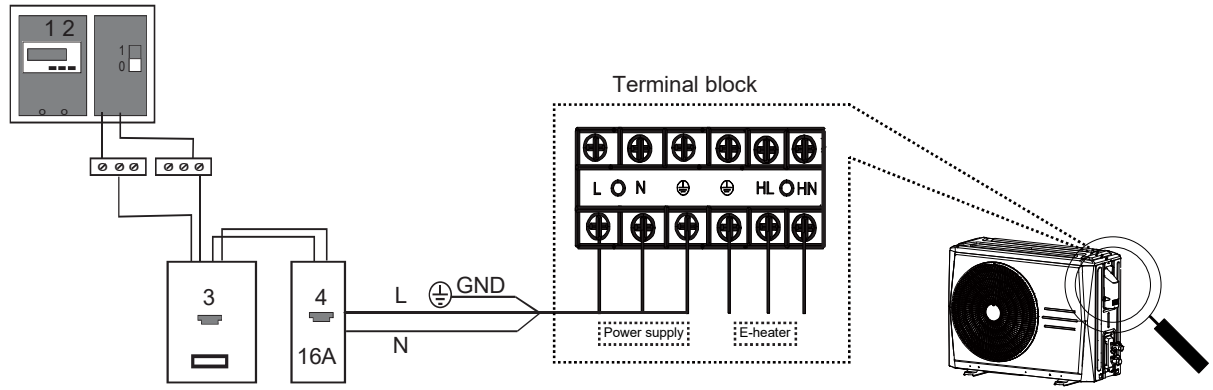

Fig. 5-4

1. Electric counter
2. Global overcurrent and leakage circuit breaker
3. Electric leakage circuit breaker
4. Overcurrent circuit breaker

⚠ CAUTION

- A leakage protector must be installed on power supply box outside the unit according to the figure above.
- Power supply with leakage protector must be installed inside or installed in the place that can satisfy water-proof requirements.
- This unit can be started only if it is grounded reliably.

5.4 Dial code definitions

💡 NOTE

The picture shown is for reference only, actual product may vary.

☐ means 0, ◼ means 1.

Table 5-2

S1-1		0	Default
		1	Reserve
S1-2		0	Without electric auxiliary heater
		1	With electric auxiliary heater
S1-3		0	Default
		1	Reserve
S2-1		0	Default
		1	Reserve (Must be set to 1 for Commercial Applications)
S2-2 S2-3		00	Default
		01	Reserve
		10	Reserve
		11	Reserve

6 CHECK

NOTE

Before switching on the unit, read following recommendations:

- When the installation and parameter setting are completed, cover all the sheet metal of the unit well.
- The unit should be maintained by professionals.

If the whole unit failed or in protection, the panel will display the corresponding code; when more than one failure or protection occurs, the order of failure protection will display. When checking, the number is displayed first, then the content. Press check button, you can go over parameters of the whole unit, the following table shows sequence of check:

Table 6-1

No.	Display content	Instructions
0	Normal display	"dF"—Defrosting "dC"—Refrigerant recovering "0"—When being shut down "—" Temperature of water tank—— When operating or standby
1	Running mode	"3"—Water heating
2	Running air speed	"F0"—Shut down fan "F1"—Low speed "F3"—High speed
3	T3 temp. value	
4	T4 temp. value	
5	T5L temp. value	
6	Th temp. value	
7	Tp temp. value	
8	Current	
9	EEV opening degree	Actual opening=display value×8
10	T5s setting temperature	
11	Td setting auto start temp. of auxiliary E-heater	
12	Trdh setting booting return difference temp.	
13	The third to last error	
14	Penultimate error	
15	The last error	
16	Software version	Actual version
17	Check finished	Display“- -"

7 OPERATIONS AND PERFORMANCES

CAUTION

Please cut off the manual switch power when unit fails. Do not restart until problems are solved.

1) Characteristics of water heating - 3 minute protection

Restart or open manual switch after the unit has been shut down within a short time. Unit will not start immediately until 3 minutes later, because of the self-protect function of the compressor.

2) During operation, if outdoor temperature is higher than normal, the fan motor will run at low air volume or stop running.

3) Defrosting function during heating operation

- In case of frosting during heating operation, to prevent the heating efficiency from decreasing, defrosting operation will turn on automatically (Approx. 2~7 minutes) .

- In the process of defrosting operation, the unit fan motor will stop running.

4) Protection device

- When protection device operates, though the unit stops, the operating indicator on the wire control will continue to blink.

- When protection device operates, indicator will display malfunction code (unit).

- Protection device will act when the following circumstances occur:

a) Air inlet or outlet are blocked.

b) Voltage is a little higher or lower compare to the voltage range (Exceeding the range of -10%~10% of 230V)

5) Starting the unit after a long period out of service

Starting up the unit after being out of service for a long period, may result in rust mixing into the water, creating water with a red colourisation flowing out from tap. This is a normal phenomenon, please ensure to continue draining water, until the colourisation disappears.

6) About power failure

- In case power failure during the unit working, please stop all operating actions.

- At the next startup after power failure, the RUN indicator on the wire controller will blink slowly for several seconds to notify user.

7) About RCCB

The condenser must use an RCCB. Please install an RCCB between the power supply and the condenser unit. In case the unit cannot act but not attribute to power failure, please check these RCCB switches at first. Before operate the RCCB, please ensure that the user installing switch is break off.

8 MAINTENANCE

8.1 Confirmation before running

- 1) Make sure whether ground wire is broken or fall off.
- 2) Turn on power supply switch for 12 hours before running.

8.2 Troubleshooting when abnormal situation happens

Before asking for serving or repairing, check the following points:

- Non-mechanical malfunction
 - 1) Water is being released from the safety valve pressure relief opening
 - When water heating, cold water will expand when heated, water being released is normal. Do not block it for safety consideration.
 - If a large amount of water flows, it means safety valve has stopped working. Stop using and replace safety valve.
 - 2) Long period for heating a tank of water
 - In winter, water heating efficiency will decrease because of low ambient temperature. It will take longer for the water heating to reach temperature.
 - If customer needs to use hot water, please start the unit in advance.
- Need to check
 - 1) Automatically start or stop
 - Whether the timer has been set incorrectly.
 - 2) When not working
 - Check whether power is on.
 - Whether manual switch is on.
 - Whether fuse has blown.
 - Whether the protection device has started (indicator lights).
 - Whether a timer has been set (operation lamp lights.)
 - 3) If heating effect is not good
 - Whether air outlet and/or inlet has been blocked.

CAUTION

- If the following situation happens, please stop running and cut off power supply manually and may contact with the dealer or service center.
 - ON/OFF operation is ineffective.
 - Fuse or RCCB trips frequently
- Before leave unused for a long time, please complete the following items:
 - Drain water from tank and pipes, close all valve bodies.
- After leave unused for a long time, please check the following items:
 - Check air inlet and outlet of the unit to see whether they are blocked. Clean immediately when they are blocked.
 - Check whether water pipes, valves have been damages or blocked. Whether there's water leakage in joints, replace them when water leaks.
 - It is suggest to inspect anode protection material every half year. If it has been exhausted, please replace it with a new one.

8.3 After-sale service

In case of malfunctions, please cut off the power switch and contact after-sale service centre or technical service department.

8.4 Important information for the used refrigerant

This product has the fluorinated gas, it is forbidden to release to air.

Refrigerant type: R134a; Volume of GWP: 1430;

GWP=Global Warming Potential

Table 8-1

Factory charge	
Refrigerant/kg	tonnes CO ₂ equivalent
0.9	1.29

NOTE

Frequency of Refrigerant Leak Checks:

- 1) For equipment that contains fluorinated greenhouse gases in quantities of 5 tonnes of CO2 equivalent or more, but of less than 50 tonnes of CO2 equipment, at least every 12 months, or where a leakage detection system is installed, at least every 24 months.
- 2) For equipment that contains fluorinated greenhouse gases in quantities of 50 tonnes of CO2 equivalent or more, but of less than 500 tonnes of CO2 equipment, at least every six months, or where a leakage detection system is installed, at least every 12 months.
- 3) For equipment that contains fluorinated greenhouse gases in quantities of 500 tonnes of CO2 equivalent or more, at least every three months, or where a leakage detection system is installed, at least every six months.
- 4) Non-hermetically sealed equipment charged with fluorinated greenhouse gases shall only be sold to the end user where evidence is provided that the installation is to be carried out by an undertaking certified person.
- 5) Only certificated person is allowed to do installation, operation and maintenance.

8.5 Water quality limitations

NOTE

If the water quality does not meet the requirements in the table below, please contact the supplier for advice.

Table 8-2

PH Value	Total Hardness	Electrical Conductivity
6.5-8.0	50ppm	<200µS/cm(25 °C)
Sulphate Ion	Silicon	Iron Content
<50ppm	<30ppm	<0.3ppm
Sulfide Ion	Chloride Ion	Ammonia Ion
None	<50ppm	None
Sodium Ion	Calcium Ion	_____
None	<50ppm	_____

9 ERROR CODE SHOOTING TABLE

Table 9-1

Error Code	Explanation
E2	Communication error
E4	Water tank temperature sensor error (T5L)
E5	ODU heat exchanger temperature sensor error (T3)
E6	ODU ambient temperature sensor error (T4)
E9	Suction temperature sensor error (Th)
EA	Discharge temperature sensor error (Tp)
EF	Clock chip error
HP	Smart Grid signal error
HC	E-heater error (Current is less than 2A when e-heater operating)
P1	High pressure protection
P2	Over load protection of fixed compressor
P4	High discharge temperature (Tp) protection
PA	Low water temperature protection
bA	The ambient temperature exceeds the declared range (not an error)
F2	Low super-heat of discharge protection
F6	Electric expansion valve joint fault
db	Anti-freezing operating (not an error) for some unit

10. Warranty

The warranty applies to Midea heat pumps installed in a single family dwelling only and is provided only to those acquiring the heat pump as consumers within the meaning of the Australian Consumer Law. The terms of the warranty are effective from the date the heat pump is installed. The validity of the product warranty period may be verified by requesting a copy of the certificate of compliance that accompanied the installation. A compliance certificate is mandatory in all Australian states.

10.1 Warranty period

1. This warranty warrants that the following heat pump components will remain free of defects for the specified periods from the date of installation:
 - Tank Cylinder - 5 years product / 3 years labour.
 - Compressor - 3 years product / 1 year labour.
 - All other components supplied, including valves, elements, thermostats and sacrificial anodes - 1 year.
2. No warranty is given in relation to components not supplied, for example tempering valves and cold water valve assemblies used by installers.
3. Subject to the conditions and exclusions specified in this warranty, the owner may have the defective heat pump component repaired or replaced covered under this warranty as soon as reasonably practicable after the consumer has reported the defect.

10.2 Consumers to register the warranty

For efficient processing of making a claim under this warranty, consumers are encourage to complete all details on the following warranty form and send it to the address indicated on the form. Alternatively warranty can be registered via the web address indicated on the form.

10.3 Procedure to make a warranty claim

Upon discovering a suspected defect, consumers should immediately report the suspected defect:

- To the installer or supplier, if the suspected defect arises as a result of the installation of the heat pump or relates to any components not covered by this warranty.
- To Chromagen during the relevant warranty period, if the suspected defect relates to any components covered by this warranty.

Please Note: To successfully make a warranty claim, Chromagen must be advised of the Heat Pumps serial number. Failure to advise serial number, may delay the service request and or prevent the service request from being processed.

10.4 Specific exclusions

To the extent permitted by law Chromagen does not accept liability under this warranty:

- If any component of the heat pump has been installed, repaired, repositioned or modified by a person other than an appropriately qualified person approved by Chromagen in accordance with the installation and maintenance instructions and relevant local and statutory requirements;
- For loss or damage caused by a fault or defect in the installation of the heat pump;
- If corrosion has occurred because the anode has not been changed in accordance with the installation & maintenance guide;

- If a cold water expansion valve, check valve and strainer is not fitted in areas where mains pressure is likely to exceed 500kPa;
- For any damage arising as a result of an accident, act of God or other circumstances beyond Chromagen's control;
- If the inner cylinder has collapsed as a result of an incorrect filling and/or commissioning procedure;
- For components not supplied by Chromagen that are used in the installation of the heat pump water heater e.g. tempering valves, cold water valve assemblies, etc.
- For extended or implied warranties not formally provided by Chromagen;
- For external labour or equipment costs (e.g. cranes and lifting devices) required for repairs;
- For costs incurred for rectifying faults (or perceived faults) not directly attributed to the heat pump water heater;
- For travel costs of service agents that exceed 30 kilometres;
- For all consequential loss or damage arising from defects that can lawfully be excluded;
- For any other issues not directly attributable to defects in components supplied by Chromagen including:
 - (a) Damage caused by incorrect commissioning;
 - (b) Leakage from valves not supplied by Chromagen;
 - (c) Leakage from the pressure temperature relief valve where the water pressure or temperature exceeds the limits specified in the installation and maintenance instructions;
 - (d) Water hammer;
 - (e) External rust on the storage tank;
 - (f) Insufficient hot water because:
 - (i) the consumer refuses to use the auxiliary booster
 - (ii) of an incorrectly set or faulty tempering or mixing valve;
 - (iii) of faulty or incomplete installation
 - (iv) the water heater is too small for its required purpose
 - (v) of insufficient water flow as a result of "water saving" tap-ware or appliances
 - (vi) of blown fuses, "tripped" electrical switches or inadequate household electrical wiring;
 - (vii) insufficient water flow caused by debris accumulating in water strainer.

10.5 Important Note

The benefits conferred by this warranty are in addition to any other rights and remedies available to the consumer under a law in relation to the goods or services to which the warranty relates.

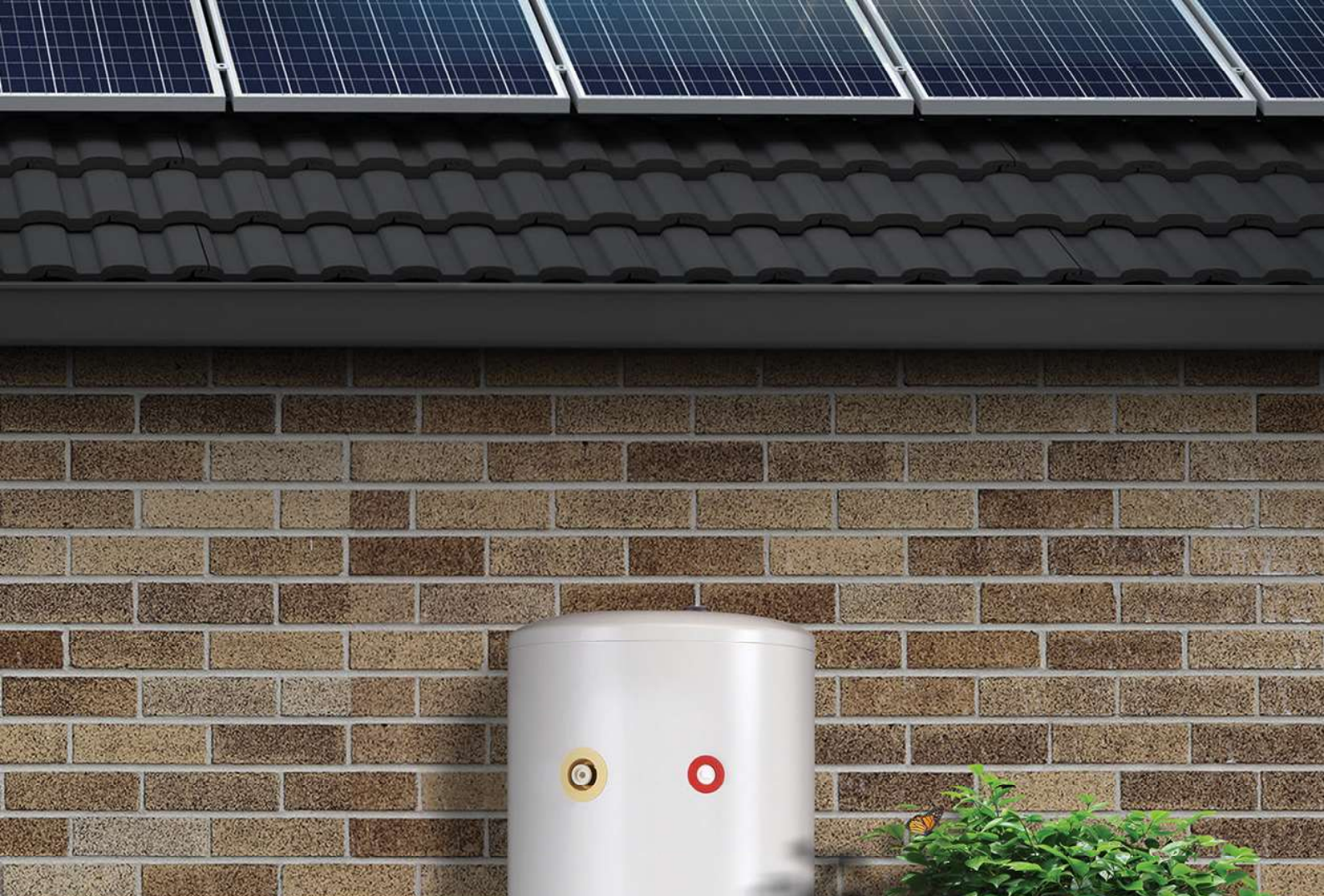

Another Hot Water Solution by 
ChromagenTM
Solar & Energy Solutions

chromagen.com.au | 1300 367 565

Hot Water Solutions | Solar Power Systems | Air Conditioning

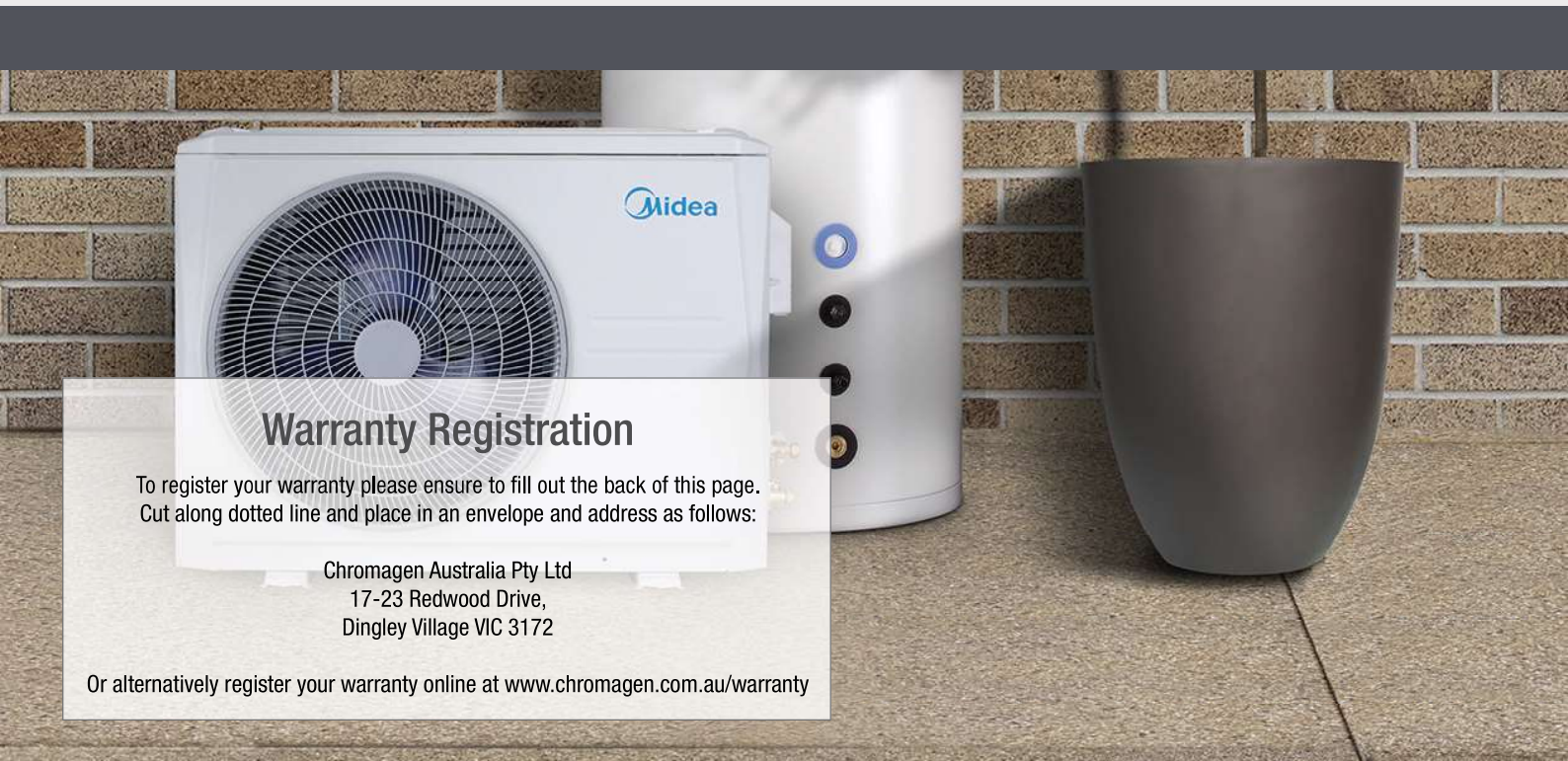

Warranty Registration

To register your warranty please ensure to fill out the back of this page.
Cut along dotted line and place in an envelope and address as follows:

Chromagen Australia Pty Ltd
17-23 Redwood Drive,
Dingley Village VIC 3172

Or alternatively register your warranty online at www.chromagen.com.au/warranty